

**MEDICAL
ILLUMINATION**
INTERNATIONAL
WHERE ILLUMINATION IS DEFINED

INSTALLATION AND SERVICE MANUAL

MI 1000



Agency Approvals



Medical Electrical Equipment
With respect to electric shock, fire
And mechanical hazards only

In accordance with UL60601-1:2006 / CAN/CSA C22.2 No.601.1-M90 with updates 1 & 2.

Classifications:

1. Protection against electrical shock (5.1,5.2). Class I permanently connected.
2. Protection against harmful ingress of water (5.3). None.
3. Degree of safety in the presence of flammable anesthetics or oxygen (5.5). Not suitable for use in the presence of flammable anesthetics or oxygen.
4. Mode of operation (5.6). Continuous.
5. Surgical luminaries (IEC60601-2-41) Minor.

Electromagnetic compatibility for immunity
And emissions in accordance with
EN-60601-1-2(2001) Class A and CISPR 22 (1997) Class A

Medical Electrical Equipment
Particular requirements for the safety of surgical
Luminaries and luminaires for diagnosis
In accordance with IEC-60601-2-41



Intended use

The MI-1000 is an AC powered device that provides a field of illumination for general examination and surgery.

Disposal of Waste



This product must not be disposed of with your other waste. Instead, it is your responsibility to dispose of your waste equipment by handing it over to a designated collection point for the recycling of waste electrical and electronic equipment, or by returning it to Medical Illumination International, Inc for reprocessing. The separate collection and recycling of your waste equipment at the time of disposal will help to conserve natural resources and ensure that it is recycled in a manner that protects human health and the environment. For more information about where you can drop off your waste equipment for recycling, please contact your local city office, your waste disposal service, or your product distributor or retailer.

Revisions

Rev.	ECO#	Pages Affected	Date
A	1162	Initial Release	10/5/10

Title	Signature	Date
President		
Vice President of Marketing		
Manufacturing Manager		
Engineering Manager		
Quality Assurance Manager		

Table of Contents

Agency Approvals.....	i
Disposal of Waste.....	ii
Revisions.....	iii
Table of Contents.....	iv
List of Figures.....	v
Section 1: Terminology.....	1
Definition of Terms.....	1
List of Symbols.....	3
Section 2: Specifications.....	4
MI-1000 Specifications.....	4
Chuttle Track Specifications.....	5
Limited Warranty.....	6
Section 3: Installation/Assembly.....	8
Ceiling Rod Calculation.....	8
Ceiling Calculation: Single Mount Dimensions.....	9
Ceiling Calculation: Double Mount Dimensions.....	10
Ceiling Mount Pre-Installation Guidelines.....	11
Ceiling Structure Construction and Mounting.....	12
Extended Ceiling Mount Installation.....	14
Single Ceiling Mount Installation.....	16
Double Ceiling Mount Installation.....	19
Wall Mounted Light Installation.....	23
Floor Stand Light Installation.....	27
Arm Assembly to Upright Pole Installation.....	29
Light Head-Arm Installation.....	30
Chuttle Track Ceiling Track Mount.....	32
Chuttle Track Pre-Installation Requirements.....	33
Disassembly of the Track Mount Before Installation.....	35
Track Mount Installation Procedure.....	38
Section 4: Operating Instructions.....	41
MI-1000 Operation.....	41
Section 5: Safety Instructions.....	42
Safety Tips.....	42
Section 6: Maintenance.....	43
LED Lamp Maintenance.....	43
Arm Adjustment.....	44
Head/Yoke Adjustment.....	45
Handle Sterilization.....	46
Cleaning Instructions.....	47
Maintenance Schedule.....	48
Section 7: Troubleshooting.....	49
General Troubleshooting.....	49

List of Figures

Figure 1. Single Ceiling Mount Ceiling Rod Calculation.....	9
Figure 2. Double Ceiling Mount Ceiling Rod Calculation	10
Figure 3. Recommended Ceiling Structure Construction.....	12
Figure 4. Ceiling Casting Mount Diagram	13
Figure 5. Extended Ceiling Mount Installation	14
Figure 6. Single Ceiling Mount Components	16
Figure 7. Single Ceiling Mount Installation.....	17
Figure 8. Double Ceiling Mount Components	19
Figure 9. Double Ceiling Mount Installation	20
Figure 10. Wire Harness Positioning	21
Figure 11. Wire Channel.....	22
Figure 12. Wall Mount Dimensions	23
Figure 13. Wall Mount Installation.....	24
Figure 14. Wall Bracket Mounting Diagram	24
Figure 15. Stud Anchor Installation.....	26
Figure 16. Floor Mount Dimensions.....	27
Figure 17. Floor Stand Base Installation.....	28
Figure 18. Arm Assembly to Upright Pole Installation.....	29
Figure 19. Light Head-Arm Installation	30
Figure 20. Light Head to Arm Electrical Connections	31
Figure 21. Track Assembly and Components.....	32
Figure 22. Mounting Pallet Perpendicular to Wood Joist	34
Figure 23. Mounting Pallet Parallel to Wood Joist	34
Figure 24. Mounting Pallet to a Suspended Ceiling.....	34
Figure 25. Suspended Ceiling Wood Bracing Detail (End View)	34
Figure 26. End Plate Removal.....	35
Figure 27. Side Panel Removal	36
Figure 28. Dress Cover Removal.....	36
Figure 29. Stop Pins Removal	37
Figure 30. Trolley Assembly Removal	37
Figure 31. Ceiling Rod and Roll Pin Installation.....	39
Figure 32. Power Cord Placement.....	40
Figure 33. MI-1000 Operation.....	41
Figure 34. Arm Adjustment	44
Figure 35. Head / Yoke Adjustment.....	45
Figure 36. Handle Sterilization.....	46

Section 1: Terminology

Definition of Terms

I.E.C.

International Electrotechnical Commission

TUV

TUV SUD America, Safety Assurance Agency

Medical Electrical Equipment

Electrical equipment intended to diagnose, treat the patient under medical supervision.
Electrical equipment that transfers energy to the patient.

Central Illuminance

Illuminance of light head measured at 1 meter from the light emitting area with no obstructions. Expressed in Foot-candles or Lux.

Light Field Center

Point of maximum illuminance in lighted area. This is the reference point for light field size and light distribution measurements.

Light Field Diameter

Diameter of the circle where illuminance reaches 10% of light field center illuminance.

Depth of Illumination

The overall distance from 1 meter where the central illuminance is reduced to 20%.

Shadow Dilution

Ability of the equipment to minimize the impact of shadows in the working area. Shadows can be due to partial obstruction by the operator or other medical personnel.

Correlated Color Temperature

The color temperature of the light fixture when compared to a blackbody radiator expressed in Kelvins.

Total Irradiance

The total amount of energy imparted to the patient by the lighting system expressed in Watts/meter squared.

Color Rendering Index (CRI)

A method of how well a light source will render other colors when illuminating them based upon eight CIE chromaticity coordinates measured with a spectroradiometer.

Sterilizable Handle

An easily removed device that maintains a sterile area in order to handle it under aseptic conditions when attached to the equipment after being properly sterilized.

Light Head

That part of the device that includes the light source, heat removal system

Articulating Arm Assembly

Light head vertical positioning arm.

Extension Arm

Horizontal section of the positioning arm with pivots on both ends that is used to increase the area covered by the light head and articulating arm.

Light Mounting

Support apparatus used to connect light head/articulating arm assembly to a fixed surface, consisting of either a single or double ceiling mount, wall mount, or track mount. Light head/articulating arm assembly may also be used with a mobile floor mount

Neutral Conductor

In an AC circuit, the return line for current.

Protective Earth Ground

The conductor used to connect the non-current-carrying metal parts of equipment, raceways, and other enclosures to the system grounded conductor, the grounding electrode conductor, or both, of the circuit at the service equipment or at the source of a separately derived system.

Ft-Lbs.

Foot-pounds. The unit of measurement of torque that is caused by an off-center load.

PSU

Power Supply Unit.

List of Symbols



TUV Listing Marking



Consult accompanying documents



C.E. Marking

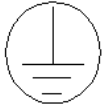

Protective Earth Ground



Caution / Warning



Electric Shock Hazard

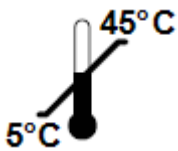

Temperature

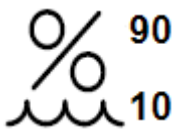

Humidity



Waste Disposal

Section 2: Specifications

*MI-1000 Specifications***Mechanical**

Parameter	Value
Weight	
Head	Approximately 13.5 lbs. (6.1 kg).
Arm	Approximately 12.5 lbs. (5.7 kg).
Arm (Floor)	Approximately 11.5 lbs. (5.2 kg).
Wall Bracket Assy.	Approximately 3.0 lbs. (1.4 kg).
Floor Stand Assy.	Approximately 43.0 lbs. (19.5 kg).
Single Ceiling Mount	Approximately 14.5 lbs. (6.6 kg).
Dual Ceiling Mount	Approximately 16.0 lbs. (7.3 kg).
Dimensions	
Head	18" (457 mm) Dia. X 4" High (102 mm)
Arm	57.0" (1448 mm) Long
Arm (Floor)	38.5" (978 mm) Long
Floor Stand	74.5" (1892 mm) High
Rotations	
Articulating Arm Vertical Movement	+/- 40 Degrees travel
Articulating Arm Horizontal Movement	Approximately 345 Degrees
Articulating Arm/Yoke Interface	Approximately 540 Degrees
Yoke/Lamp Head Interface	Approximately 190 Degrees

Electrical

Parameter	Value
Input Voltage	100 – 240 VAC 50/60 Hz
Power Consumption	Approx 60W max
LED life	50,000 hours (average)

Optical

Parameter	Value
36 Inner optics + 6 Outer optics	Clear acrylic, multi-source
Performance	
Color temperature	4000 K
Focal length	39" (1 meter)
Central illuminance (full intensity)	6500 foot-candles (70000 Lux)
Dimming – 5 levels	100% 87% 75% 63% 50% of full intensity 70k 62k 53k 44k 35k Lux
Light field diameter (d10)	Approx 9"
Light field diameter (d50)	Approx 5"
Depth of illumination	Approx 50"
Shadow Dilution	
Illuminance (one mask)	Approx 2100 foot-candles
Illuminance (two masks)	Approx 2800 foot-candles
Illuminance (tube with one mask)	Approx 2100 foot-candles
Illuminance (tube with two masks)	Approx 2800 foot-candles
Irradiance	Approx 22.6 W/m ²
CRI	≥85

Environmental

Parameter	Value
Operating Temperature	41-104 °F (5-40 °C)
Storage Temperature Range	41-113 °F (5-45 °C)
Humidity	10 - 90% Relative Humidity

Chuttle Track Specifications**Mechanical**

Parameter	Value
Weight Single Track Assembly Dual Trolley Model	Approximately 44.0 lbs. (20 kg). Approximately 48.0 lbs. (22 kg).
Dimensions Track (standard)	72" (1829 mm) Long X 10 ½" Wide (267 mm) X 5" (127 mm) High

Electrical

Power cable exiting the track can be connected to 100-240VAC, 50/60 Hz power. The power supply routed to the track must be a 3 wire grounded type capable of supplying:

Single Trolley	Single Ceiling	60 W @ 1A
	Double Ceiling	120 W @ 2A
Dual Trolley	2x Single Ceiling	120 W @ 2A
	2x Double Ceiling	240 W @ 4A
	1x Single, 1x Double	180 W @ 3A

NOTE: Refer to Model/Serial label located on the arm assembly that will be mounted to the track for proper voltage supply.

Limited Warranty
Medical Illumination International, Inc. - Lighting Equipment

This document comprises the general terms of your product's Limited Warranty. By accepting the shipment of the product, the owner/purchaser agrees to adhere to the warranty terms and conditions expressed herein.

Medical Illumination International, Inc. ("Medical Illumination") Lighting Equipment is warranted against defective material and/or workmanship, excluding normal replacement parts (e.g. bulbs, sterilizable handles or glass items), for a period of three (3) years from the date of shipment. This Limited Warranty applies exclusively to the repair or replacement of parts recognized as defective by Medical Illumination, are in normal use, and have not been modified or repaired by unauthorized personnel.

This Limited Warranty extends only to the first retail purchaser of a product, and is not transferable or assignable. This warranty supersedes all other guarantees or warranties, expressed or implied.

WARRANTY SERVICE & REPAIRS

Medical Illumination does not provide (or give any compensation for) outside repair services or field labor. Therefore, in the event of a failure covered under this warranty, please take the following immediate action:

1. Contact Medical Illumination via phone at (818) 838-3025, through our website at <http://www.medillum.com>, or by facsimile at (818) 838-3725.
 - A. Be prepared to give the model number, serial number, and full description of the failure.
 - B. Our Customer Service department will attempt to solve the problem over the phone. If it becomes necessary to send the product to the factory for repair, you will be provided with a Return Authorization number. Products sent to the factory without a Return Authorization number will not be accepted.
2. It is the retail purchaser's obligation to arrange for shipment return of a product to the factory for warranty service, which shall be at the retail purchaser's expense. Carefully package the light component (light head, arm assembly, mount assembly, etc.) and return it, freight prepaid and insured, with the Return Authorization number clearly marked on the outside of the box, to:

Medical Illumination
547 Library Street
San Fernando, CA 91340
RA# _____

Limited Warranty (cont.)

Damage resulting from inadequate packing is not covered by this warranty, and shipping insurance does not cover damage due to inadequate packing. We recommend that the package be insured against loss or in-transit damage. Medical Illumination cannot be held responsible for in-transit loss or damage. In the event that freight-related damage should occur, Medical Illumination will notify you immediately so that you can file a damage claim with the proper freight carrier.

Within the aforementioned time period of three (3) years from date of shipment, Medical Illumination will evaluate the returned product, repair as appropriate, and ship the product back to you with freight costs prepaid by the Company. In the event that non-warranty damage or failure is discovered, you will be contacted before any repairs are performed.

EXCLUSIONS

This Limited Warranty does not cover the following:

- Any field labor or outside services (electricians, contractors, installation services, routine maintenance or other repair services).
- Damage to the product resulting from tampering, accident, abuse, negligence, alteration, or other causes unrelated to problems with material and/or workmanship;
- Damage due to improper installation, use, cleaning or maintenance, as outlined in the Installation and Service Manual for the product;
- Labor costs associated with removing, re-packaging for shipment or reinstalling product;

PRODUCT RETURNS:

Please contact the authorized dealer from whom the product was purchased to inquire about a product return. Additional terms and conditions set by the dealer may apply for any returned items.

SHIPMENT DAMAGE:

If the initial shipment of your purchased product arrived in damaged condition, please file a claim with the carrier and contact Medical Illumination immediately.

Section 3: Installation/Assembly

Ceiling Rod Calculation

Use the following table to select the correct length ceiling rod for your application.

Ceiling Mounting Height		Base Rod	Ext. Rod	Ext. Mnt. Kit	
7'10" - 8'6"	(94" - 102")	16"	-	-	Base Rod Only
8'7" - 9'4"	(103" - 112")	25"	-	-	
9'5" - 10'1"	(113" - 121")	35"	-	-	
10'2" - 10'10"	(122" - 130")	16"	34"	1000976-44	Extension Rod Needed
10'11" - 11'8"	(131" - 140")	25"	34"	1000976-53	
11'9" - 12'0"	(141" - 144")	35"	34"	1000976-63	
12'1" - 12'10"	(145" - 154")	25"	48"	1000976-67	
12'11" - 14'0"	(155" - 168")	35"	48"	1000976-77	

Ceiling Calculation: Single Mount Dimensions



Use the following table to select the correct length ceiling rod for your application.

Ceiling Rod Calculation, Single Ceiling Mount

Ceiling Mounting Height (Y-Value)	Ceiling Rod Length	"X" Value	Head room to bottom of extension arm (y-value - x-value)
7'10" - 8'6"	16"	22"	6'2" - 6'11"
8'7" - 9'4"	25"	31"	6'2" - 7'0"
9'5" - 10'1"	35"	41"	6'2" - 6'11"
10'2" - 10'10"	44"	50"	6'2" - 6'11"
10'11" - 11'8"	53"	59"	6'2" - 7'0"
11'9" - 12'0"	63"	69"	6'2" - 6'6"
12'1" - 12'10"	67"	73"	6'2" - 7'0"
12'11" - 14'0"	77"	83"	6'2" - 7'3"

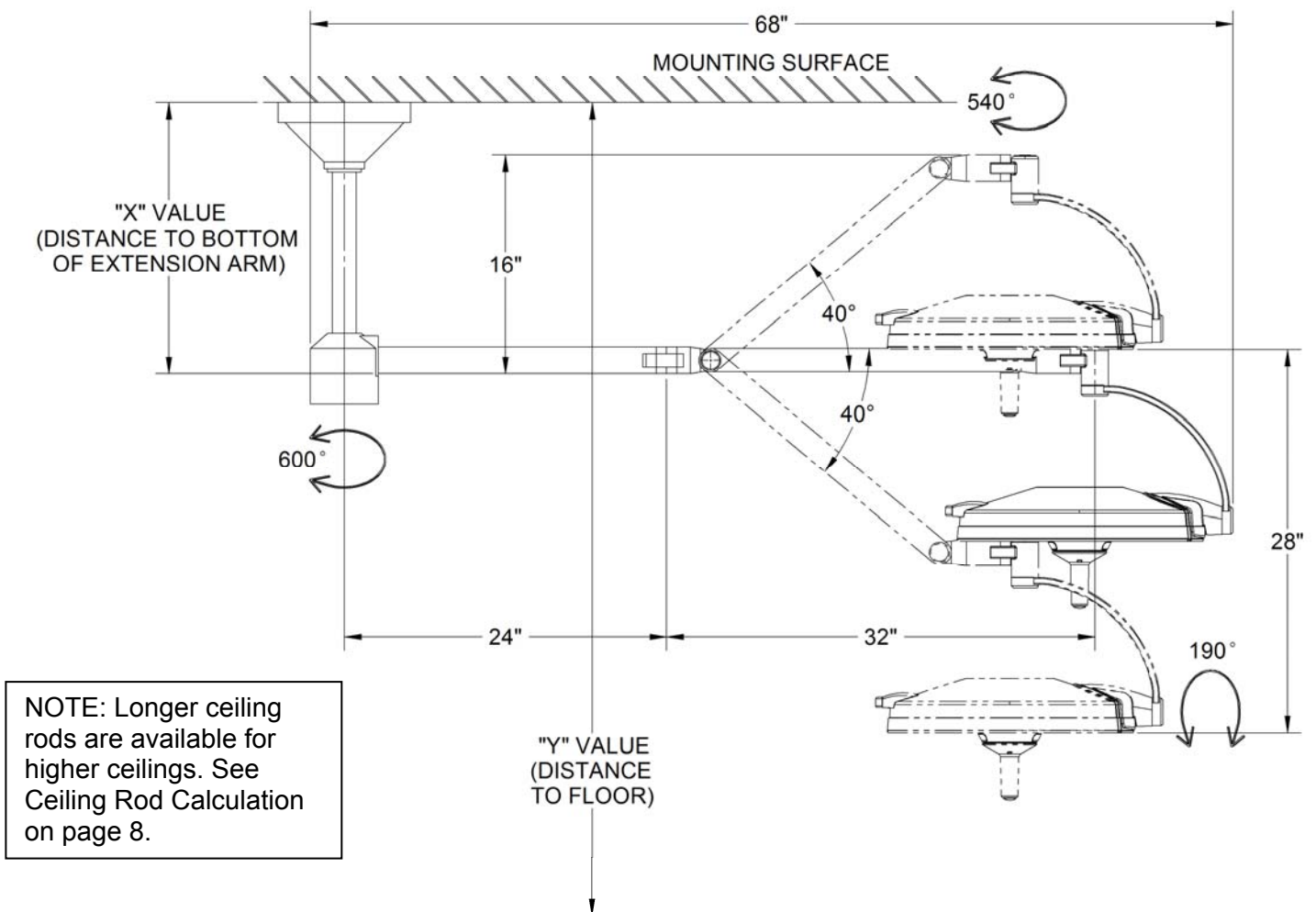

Figure 1. Single Ceiling Mount Ceiling Rod Calculation

Ceiling Calculation: Double Mount Dimensions



Use the following table to select the correct length ceiling rod for your application.

Ceiling Rod Calculation, Double Ceiling Mount

Ceiling Mounting Height (Y Value)	Ceiling Rod Length	"X" Value	Head room to bottom of extension arm (y-value – x-value)
7'10" - 8'6"	16"	23"	6'1" - 6'10"
8'7" - 9'4"	25"	32"	6'1" - 6'11"
9'5" - 10'1"	35"	42"	6'1" - 6'10"
10'2" - 10'10"	44"	51"	6'1" - 6'10"
10'11" - 11'8"	53"	60"	6'1" - 6'11"
11'9" - 12'0"	63"	70"	6'1" - 6'5"
12'1" - 12'10"	67"	74"	6'1" - 6'11"
12'11" - 14'0"	77"	84"	6'1" - 7'2"

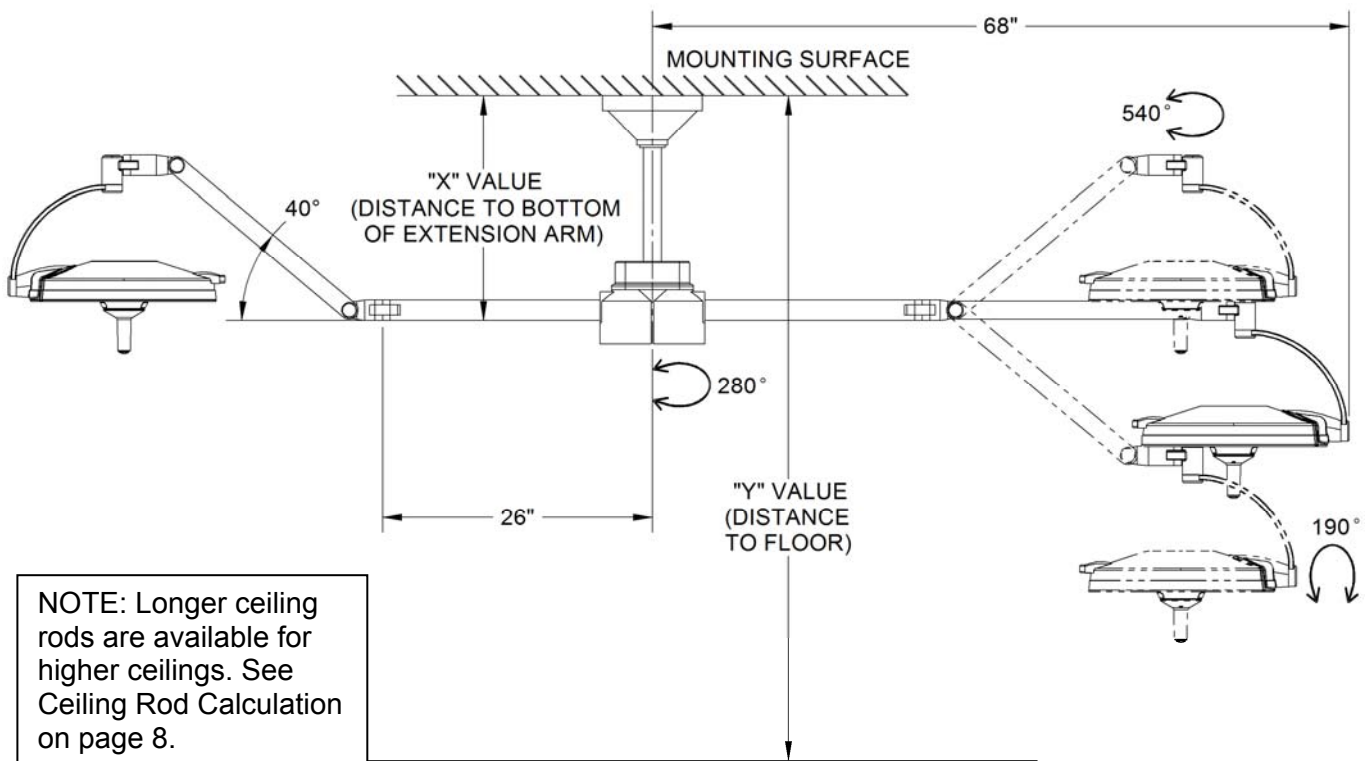

Figure 2. Double Ceiling Mount Ceiling Rod Calculation

Ceiling Mount Pre-Installation Guidelines

SPECIAL NOTE: Installation and repair of this equipment should be performed by qualified persons only. Medical Illumination International, Inc. does not warranty any damage occurring as a result of improper installation. It is recommended that this installation manual be completely reviewed prior to installation.

Before installation, check to insure the following minimum conditions are provided:

Ceiling Mount	Weight: Lb	Moment: Ft Lb
Single Ceiling	70	215
Double Ceiling	115	350

← recommended

Medical Illumination strongly recommends that the ceiling structure be designed to the weights and moments for the worst case (double ceiling). Designing for the heaviest model with the highest load/torque will provide adequate support for the heaviest, and will not significantly increase the cost of the lightest. The design margin will also allow for flexibility for future product upgrades.



A structural mount that does not meet these minimum conditions can cause serious injury and/or property damage.

- The ceiling structure must be strong enough to support the weight and rigid enough to constrain rotation to less than 0.1° at the ceiling casting.
- The equipment may be mounted directly over a 4-0 junction box. Input power supply lines should be wired in accordance with all applicable building codes.
- The supply circuit line must be as follows:
100-240VAC, 50/60 Hz, single phase, three wire, capable of supplying 240 Watts @ 4A.
- The equipment is not deemed compatible with any sort of electrical dimming device. Use line voltage only.
- The power supply circuit line must be routed and wired to the wire harness in compliance with all applicable building codes.



Failure to provide a circuit meeting these minimum standards or complying with local building codes can cause a shock hazard.

- Check the length of the ceiling rod supplied to make sure that it is the proper length to install and operate the light without interference or over reach (See Figure 1 or Figure 2).

Ceiling Structure Construction and Mounting

The Ceiling Mount system will experience various level of dynamic off center moment during regular use. Therefore, it is crucial that the ceiling structure to be strong enough to uphold the weight of the system and support the positioning arms and light head without deflection. The owner and/or owner's contractor has the final responsibility for the strength and rigidity of the ceiling structure. An inadequate ceiling may result in unintended drift and/or equipment damage.

Because the ceiling structure is the owner's responsibility, the design and construction recommendation shown below (see Figure 3. Recommended Ceiling Structure Construction) covers only one of the many possible alternatives that can be used. Medical Illumination highly recommends that the owner consult a structural engineer prior to designing and installing the ceiling structure.

Recommended Ceiling Structure Construction Details

The illustrations below are suggested mounting schemes per 2001 California Building Code – Section 1632A: Anchorage and Seismic. For any other mounting scheme, please consult a structural engineer and/or professional contractor for the best solution for your situation. Installation and repair of this equipment should be performed by qualified persons only. Medical Illumination does not warranty any damage occurring as a result of improper installation.

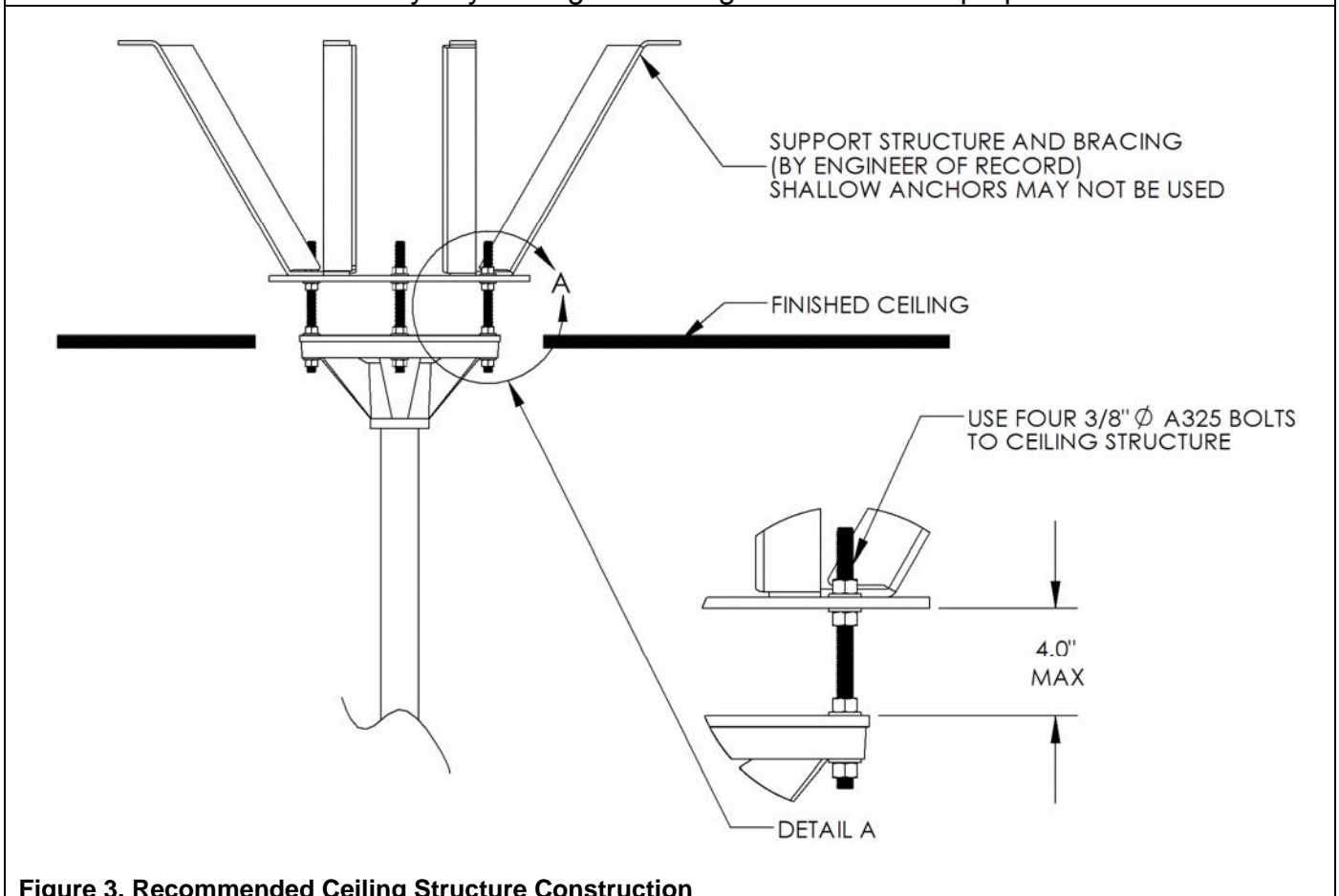

Figure 3. Recommended Ceiling Structure Construction

Ceiling Structure Construction and Mounting

⚠ Improper fastening of the ceiling casting can cause serious injury and/or property damage.

- Mount the Ceiling casting to the ceiling structure using four $\frac{3}{8}$ " DIA A325 bolts with nuts and washers as shown in Figure 3. Recommended Ceiling Structure Construction.

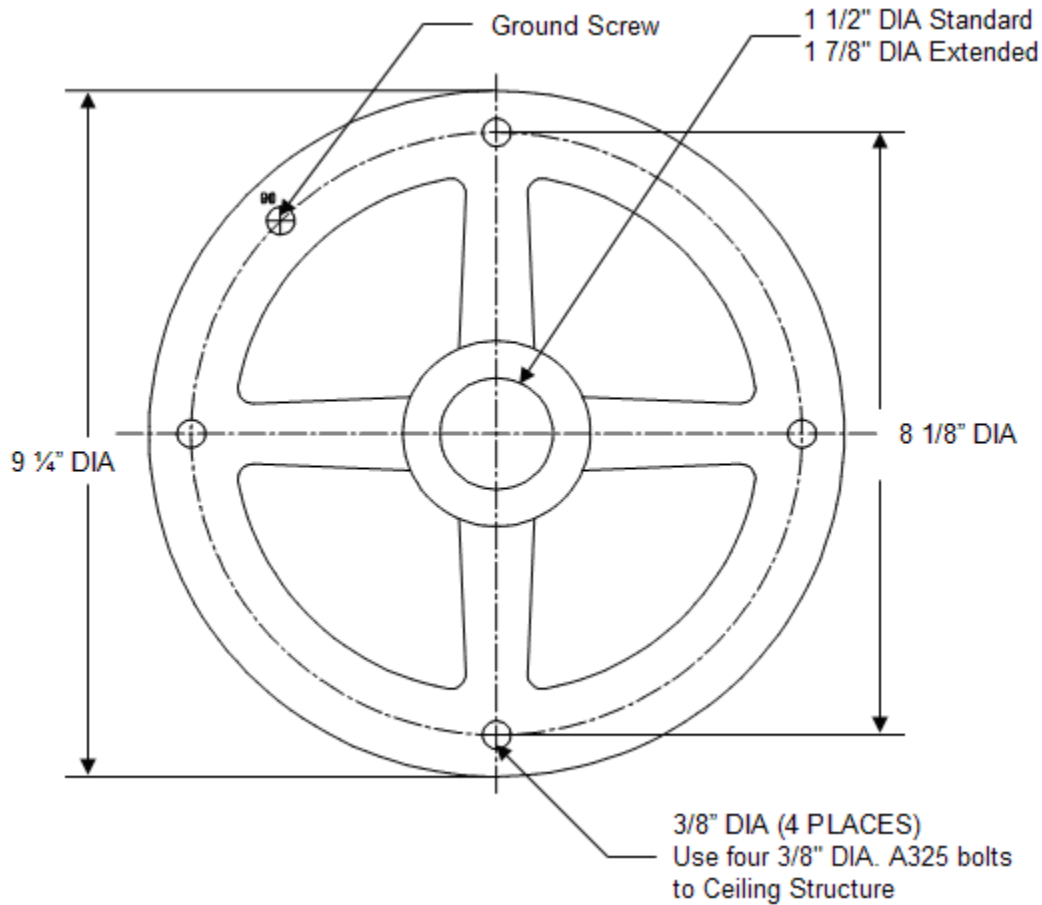

Figure 4. Ceiling Casting Mount Diagram

**Extended Ceiling Mount Installation
For 10'2" – 14' (3.23m-4.27m) Ceilings**

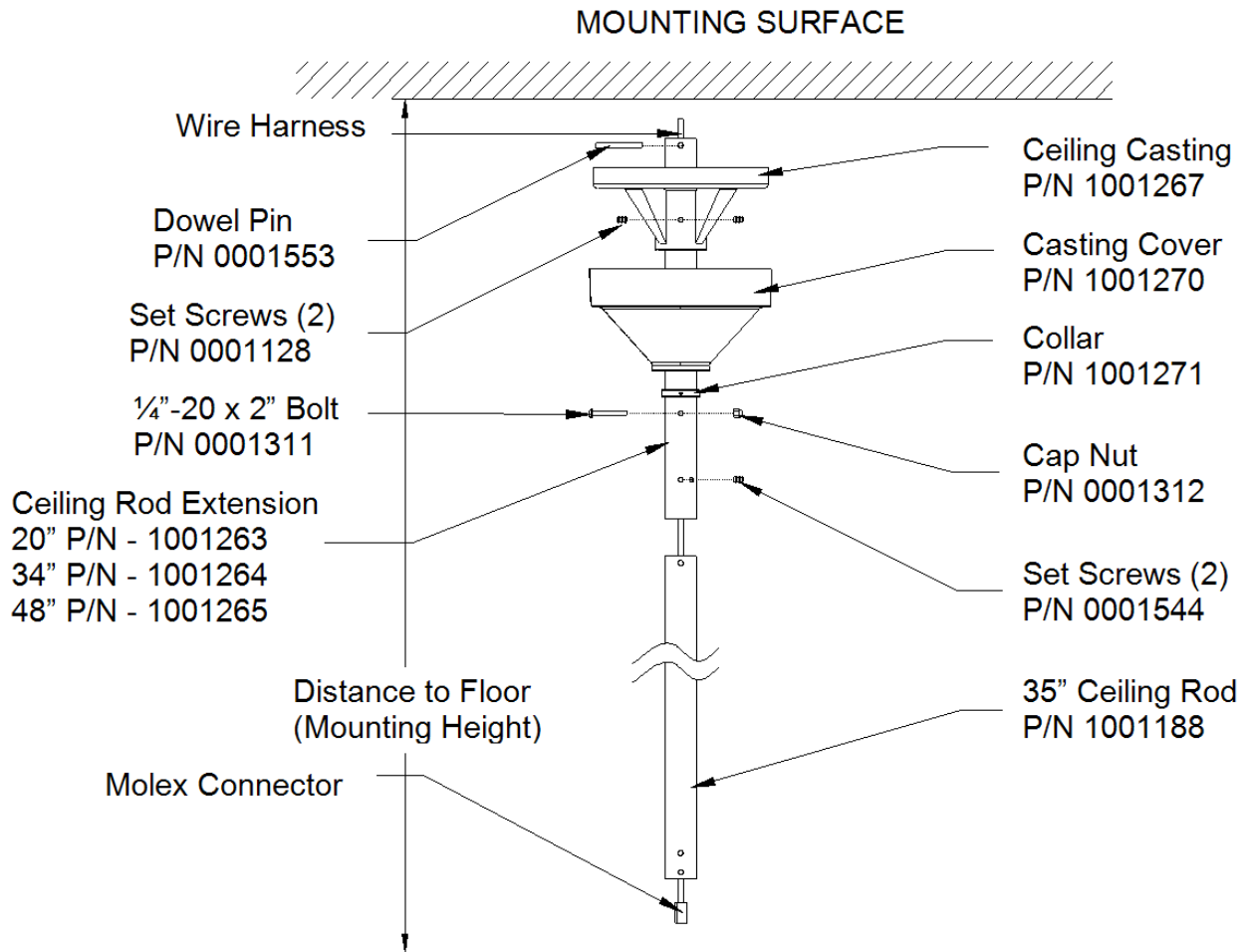

Figure 5. Extended Ceiling Mount Installation

Insert the ceiling rod up through the ceiling casting until the hole in the ceiling rod becomes visible (see

- Figure 5. Extended Ceiling Mount Installation). Insert the dowel pin into the hole in the ceiling rod and lower the rod in the ceiling casting, making sure the pin is seated securely in the indentation on the ceiling casting. Securely tighten the two set-screws located in the casting.



Failure to install the dowel pin can cause the arm/head assembly to fall from the ceiling causing serious injury and/or property damage.

The ceiling casting must be properly grounded during installation. This can be done by mounting the casting to a suitable material that will function as a ground conductor, or a wire lead that must be attached to the ground screw on the casting then routed to proper ground (see

- Figure 4. Ceiling Casting Mount Diagram).

Note: Ceiling rod must be plumb. Adjust the nuts/washers in Figure 3 accordingly.

Note: The ceiling casting itself must be electrically grounded to maintain proper grounding reliability.



If ceiling rod is not plumb, unwanted arm drifting may occur.

- Feed the wire harness through the ceiling rod extension and route to a junction box. Leave sufficient wire to extend slightly beyond the bottom of the ceiling rod. **Important: To achieve proper grounding reliability, the green ground wire from the wire harness MUST be properly fastened to the grounding screw located on the ceiling casting (see**
- **Figure 4. Ceiling Casting Mount Diagram). Make all electrical connections in compliance with all applicable electrical codes.**



Failure to comply with local electrical codes can cause a shock hazard.

- Slide the casting cover up the rod extension and over the casting. Similarly, slide the collar to the casting cover, then tighten the set screw to hold the cover in place.
- Feed the wire harness through the 35" ceiling rod with the rod in the direction shown. Slide ceiling rod up through ceiling rod extension until the holes in the ceiling rod align with the upper holes in the ceiling rod extension. Insert a 1/4"-20 x 2" bolt carefully, making certain not to damage the wire harness, and then fasten the cap nut. Secure rods in place with the two set screws provided.
- See Single Ceiling Mount Installation (page 16) or Double Ceiling Mount Installation (page 19) and to complete the assembly.

Single Ceiling Mount Installation

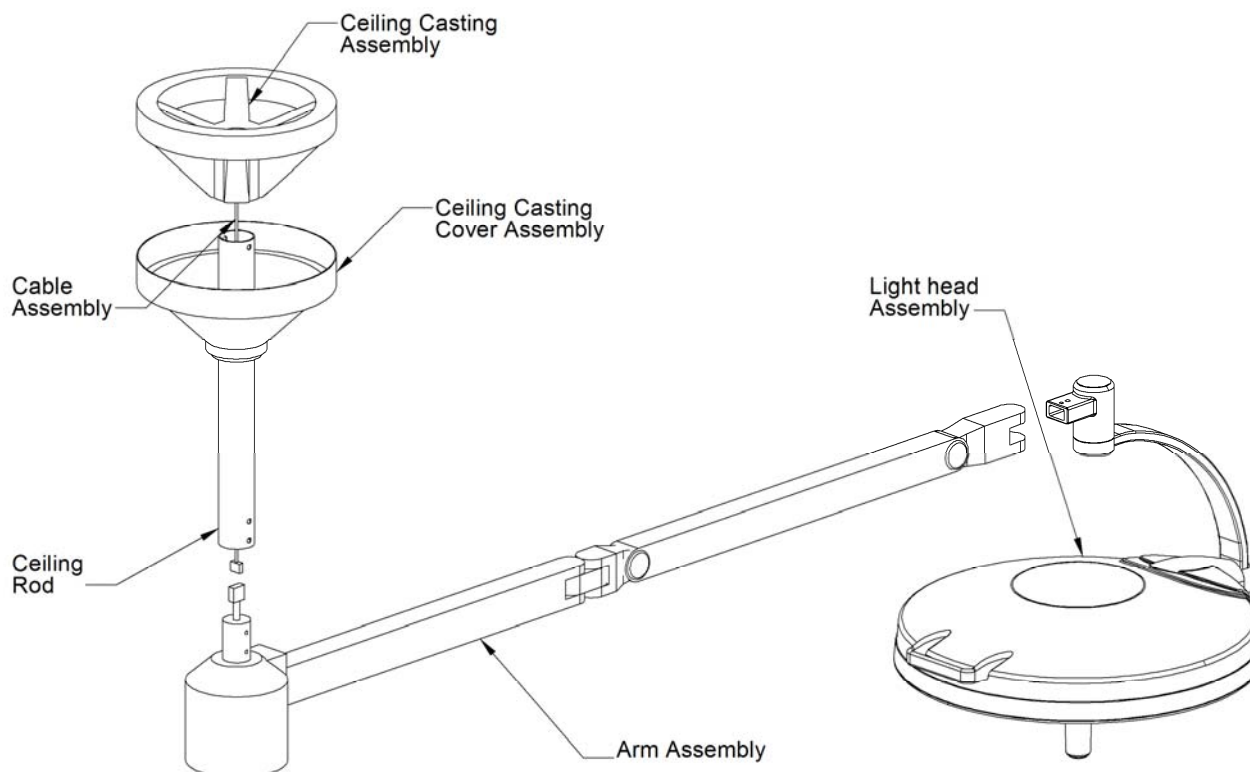

Figure 6. Single Ceiling Mount Components

GENERAL INFORMATION

⚠ Installation and repair of this equipment should be performed by qualified persons only. Medical Illumination does not warranty any damage occurring as a result of improper installation.

The shipping cartons contain a light head assembly, an arm assembly, a ceiling casting, casting cover, collar, bolt cover, ceiling rod, hardware kit, wire harness, and an Installation and Service Manual.

Notes: There are 3 standard length rods for different ceiling heights. Extended ceiling rod kits are available for ceilings over 10'2". Verify that your ceiling rod length is correct for your ceiling height (see "Ceiling Rod Calculation" on page 8). If not correct please contact customer service.

Prior to installation insure that all components shown in "Figure 6. Single Ceiling Mount Components" are present.

⚠ When removing parts from the shipping carton, be careful not to damage the components. Important: thoroughly check each box for parts that may be located in areas that can be overlooked.

Single Ceiling Mount Installation

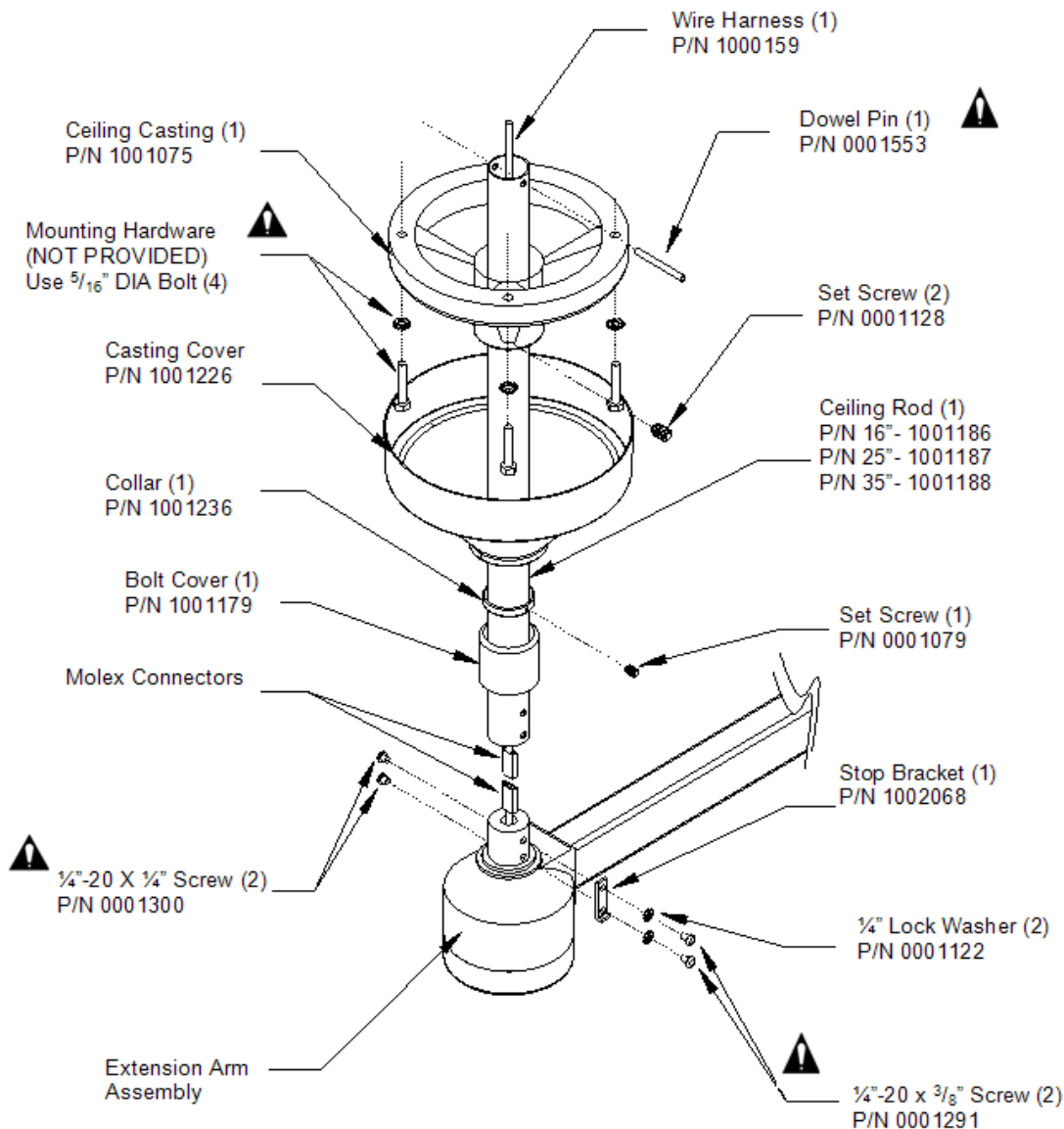

Figure 7. Single Ceiling Mount Installation

- Insert the ceiling rod up through the ceiling casting until the hole in the ceiling rod becomes visible (see Figure 7. Single Ceiling Mount Installation). Insert the dowel pin into the hole in the ceiling rod and lower the rod in the ceiling casting, making sure the pin is seated securely in the indentation on the ceiling casting. Securely tighten the two set-screws located in the casting.



Failure to install the dowel pin can cause the arm/head assembly to fall from the ceiling causing serious injury and/or property damage.

The ceiling casting must be properly grounded during installation. This can be done by mounting the casting to a suitable material that will function as a ground conductor, or a wire lead that must be attached to the ground screw on the casting then routed to proper ground (see

- Figure 4. Ceiling Casting Mount Diagram).

Note: Ceiling rod must be plumb. Adjust the nuts/washers in Figure 3 accordingly.

Note: The ceiling casting itself must be electrically grounded to maintain proper grounding reliability.



If ceiling rod is not plumb, unwanted arm drifting may occur.

- Feed the wire harness through the ceiling rod extension and route to a junction box. Leave sufficient wire to extend slightly beyond the bottom of the ceiling rod. **Important: To achieve proper grounding reliability, the green ground wire from the wire harness MUST be properly fastened to the grounding screw located on the ceiling casting (see**
- **Figure 4. Ceiling Casting Mount Diagram). Make all electrical connections in compliance with all applicable electrical codes.**



Failure to comply with local electrical codes can cause a shock hazard.

- Slide the casting cover up the rod over the casting. Similarly, slide the collar to the casting cover, then tighten the set screw to hold the cover in place. Feed the wire harness through the ceiling rod with the rod in the direction shown.



Do not install the extension arm with the light head attached. Installation with the light head attached can cause damage to the light. Refer to the procedure for installing the head to the arm after the bracket and arm are installed.

- Slide the bolt cover up onto the ceiling rod as shown in Figure 7, then raise the extension arm to the ceiling rod and plug the Molex connectors together. Push the wire into the ceiling rod while inserting the transformer housing into the rod. Secure the housing to the ceiling rod using the four supplied bolts as shown. Two 1/4"-20 x 1/4" screws must be installed on one side of the ceiling rod. Two 1/4"-20 x 3/8" screws and lock washers must be used to mount the stop bracket on the other side of the rod. Be sure the bend on the stop faces down, towards the arm.



Failure to install the stop clip subassembly can cause damage to the light fixture.



Failure to install or tighten the 1/4"-20 socket head cap screw can cause the arm/head assembly to fall causing serious injury and/or property damage.

- Complete the installation by lowering the bolt cover onto the transformer housing.
- See the instructions for "Light Head-Arm Installation" on page 30 to complete the assembly.

Double Ceiling Mount Installation

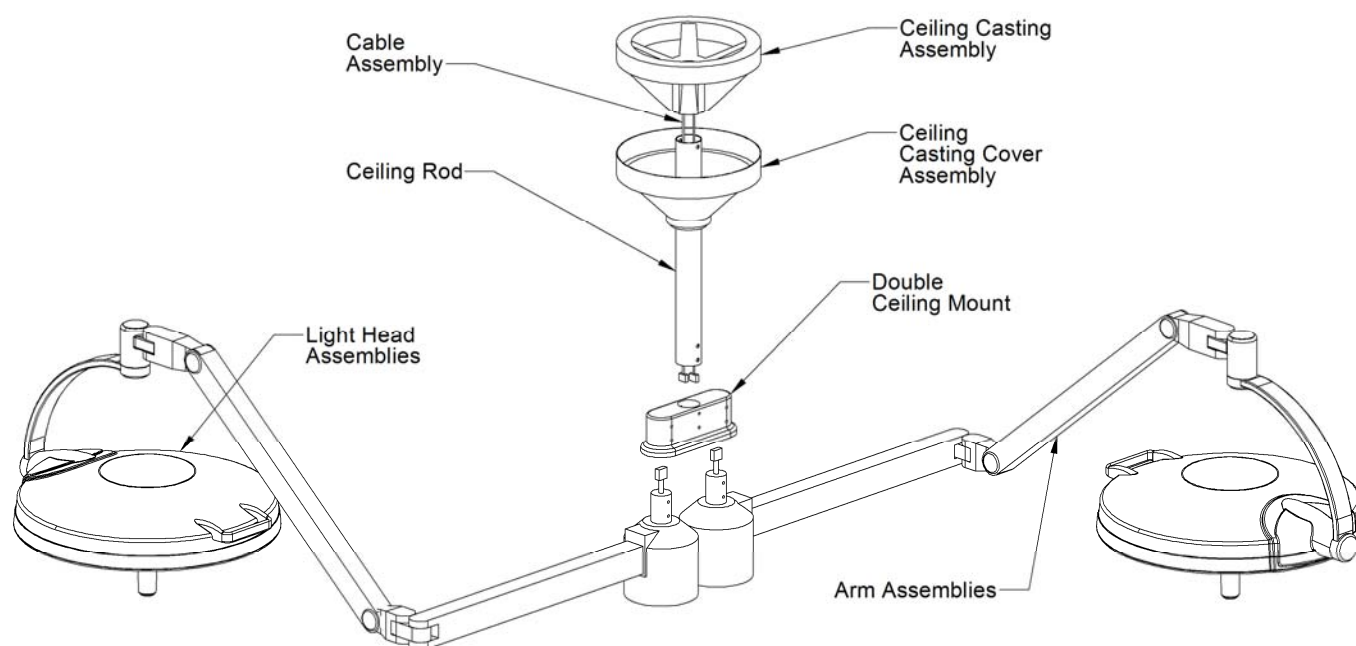

Figure 8. Double Ceiling Mount Components

GENERAL INFORMATION

! Installation and repair of this equipment should be performed by qualified persons only. Medical Illumination does not warranty any damage occurring as a result of improper installation.

The shipping cartons each contain a light head assembly and an arm assembly. One of the cartons also contain a ceiling casting, casting cover, collar, ceiling rod, double mount assembly, hardware kit, wire harness, and an Installation and Service Manual.

Notes: There are 3 standard length rods for different ceiling heights. Extended ceiling rod kits are available for ceilings over 10'6". Verify that your ceiling rod length is correct for your ceiling height (see "Ceiling Rod Calculation" on page 8). If not correct please contact customer service.

Prior to installation insure that all components shown in "Figure 8. Double Ceiling Mount Components" are present.

! When removing parts from the shipping carton, be careful not to damage the components. Important: thoroughly check each box for parts that may be located in areas that can be overlooked.

Double Ceiling Mount Installation

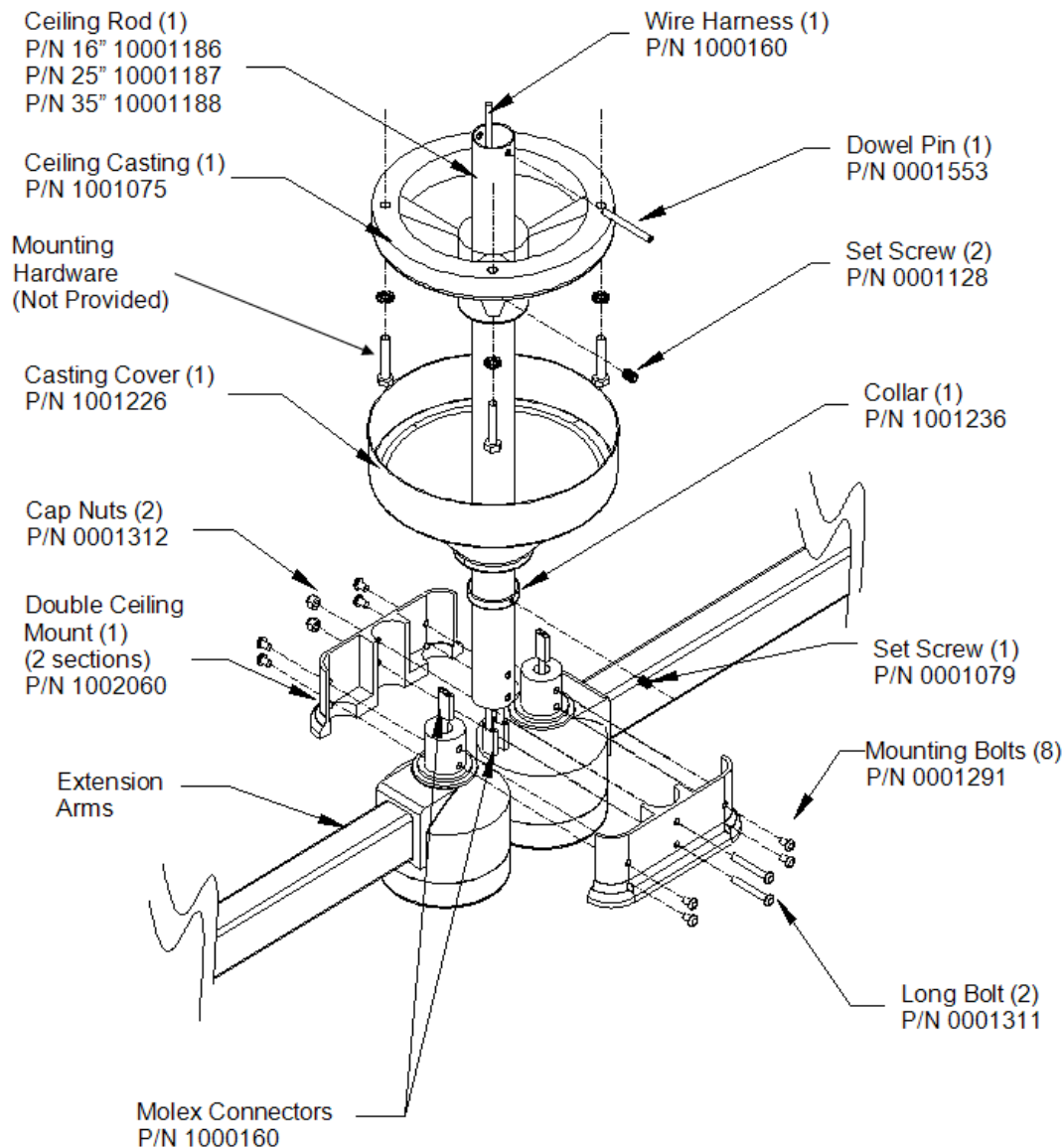

Figure 9. Double Ceiling Mount Installation

- Insert the ceiling rod up through the ceiling casting until the hole in the ceiling rod becomes visible (see Figure 9. Double Ceiling Mount Installation). Insert the dowel pin into the hole in the ceiling rod and lower the rod in the ceiling casting, making sure the pin is seated securely in the indentation on the ceiling casting. Securely tighten the two set-screws located in the casting.



Failure to install the dowel pin can cause the arm/head assembly to fall from the ceiling causing serious injury and/or property damage.

The ceiling casting must be properly grounded during installation. This can be done by mounting the casting to a suitable material that will function as a ground conductor, or a wire lead that must be attached to the ground screw on the casting then routed to proper ground (see

- Figure 4. Ceiling Casting Mount Diagram).

Note: Ceiling rod must be plumb. Adjust the nuts/washers in Figure 3 accordingly.

Note: The ceiling casting itself must be electrically grounded to maintain proper grounding reliability.



If ceiling rod is not plumb, unwanted arm drifting may occur.

- Feed the wire harness through the ceiling rod extension and route to a junction box. Leave sufficient wire to extend slightly beyond the bottom of the ceiling rod. **Important: To achieve proper grounding reliability, the green ground wire from the wire harness MUST be properly fastened to the grounding screw located on the ceiling casting (see**
- **Figure 4. Ceiling Casting Mount Diagram). Make all electrical connections in compliance with all applicable electrical codes.**



Failure to comply with local electrical codes can cause a shock hazard.

- Slide the casting cover up the rod over the casting. Similarly, slide the collar to the casting cover, then tighten the set screw to hold the cover in place. Feed the wire harness through the ceiling rod with the rod in the direction shown.



Do not install the extension arm with the light head attached. Installation with the light head attached can cause damage to the light. Refer to the procedure for installing the head to the arm after the bracket and arm are installed

- Bring one section of the double ceiling mount casting to the ceiling rod and fasten it to the rod with the 2" long bolts (P/N 0001311) and cap nuts (P/N 0001312). Tighten the cap nuts just enough to hold the section in place; they do not need to be fully tightened at this time. Bring an arm assembly to the double mount section and fasten the transformer housing into the extension arm mounting cavity with two $\frac{3}{8}$ " long mounting screws (P/N 0001291). Install the other arm assembly to the section with two more $\frac{3}{8}$ " long screws. Route the wire and Molex connector from the ceiling rod into the wire channel as shown in "Figure 10. Wire Harness Positioning" and "Figure 11. Wire Channel". Plug the connector at the end of each arm assembly to the mating Molex connector from the wire harness. Place each set of wires within the channel area.

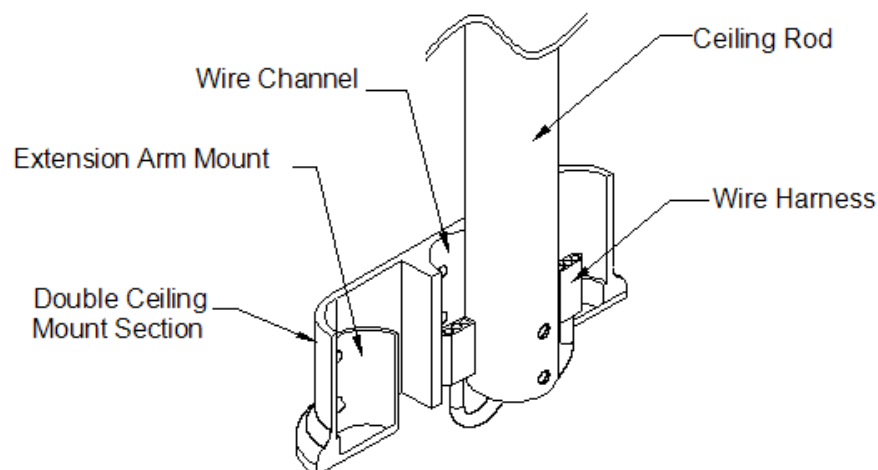

Figure 10. Wire Harness Positioning

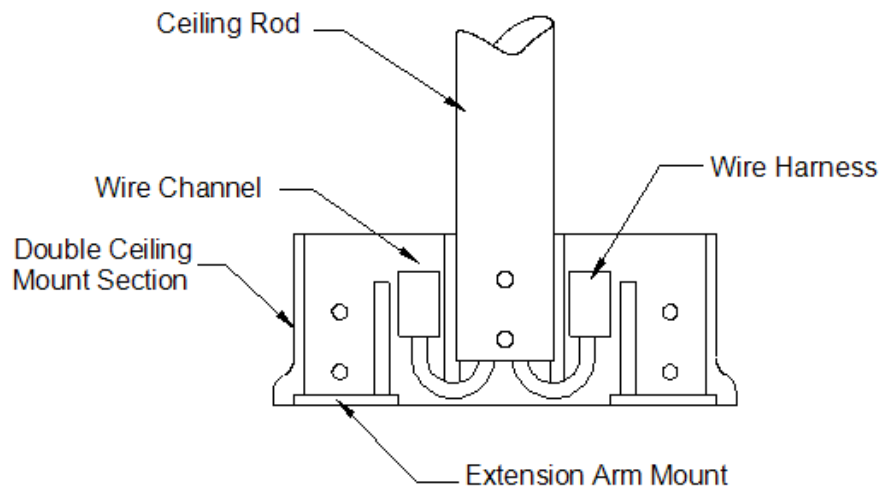

Figure 11. Wire Channel

- Position the two extension arms as shown in “Figure 9. Double Ceiling Mount Installation” to allow for easier mounting of the remaining double mount section. Firmly press the fastened double ceiling mount section against the ceiling rod. While firmly holding the double ceiling mount section with arms attached in place, remove only the cap nuts from the 2” long bolts. It is strongly recommended that a second person hold the arms in place while the nuts are removed. Place the remaining double ceiling mount section onto the bolts. Be sure the wires are enclosed within the wire channel to avoid pinching them. Replace the cap nuts and fully tighten. Install the remaining four $\frac{3}{8}$ ” long mounting screws and then fully tighten all eight screws.



Failure to tighten the cap nuts for the 2” long bolts can cause the arm/head assembly to fall causing serious injury and/or property damage.



Failure to install or tighten all eight of the $\frac{3}{8}$ ” mounting screws can cause the arm/head assembly to fall causing serious injury and/or property damage.

- Check to make sure that the wire connections are seated far enough into the double casting enclosure. Fasten the cover plates to the casting enclosure using the four $\frac{3}{8}$ ” long pan-head screws (P/N 0001319) and plastic grommets (P/N 0001306) supplied in the hardware kit.
- See the instructions for “Light Head-Arm Installation” on page 30 to complete the assembly.

Wall Mounted Light Installation

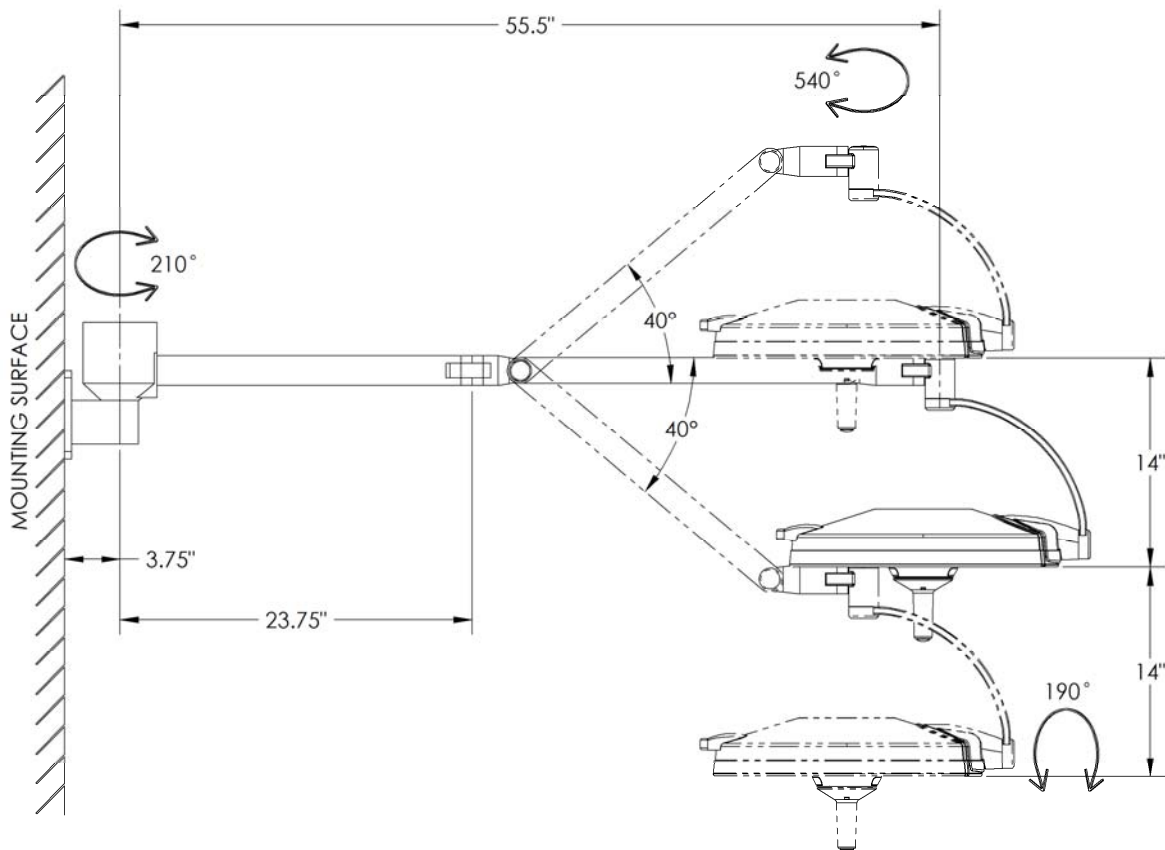

Figure 12. Wall Mount Dimensions

GENERAL INFORMATION

The shipping cartons contain a light head assembly, arm assembly, a wall bracket assembly with a hospital grade plug attached, hardware kit, and an Installation and Service Manual. (Mounting hardware for attaching the wall bracket to the wall is not supplied).

Prior to installation ensure that all components shown on "Figure 13. Wall Mount Installation" are present.



When removing parts from the shipping carton, be careful not to damage the components. Important: thoroughly check each box for parts that may be located in areas that can be overlooked.

Wall Mounted Light Installation

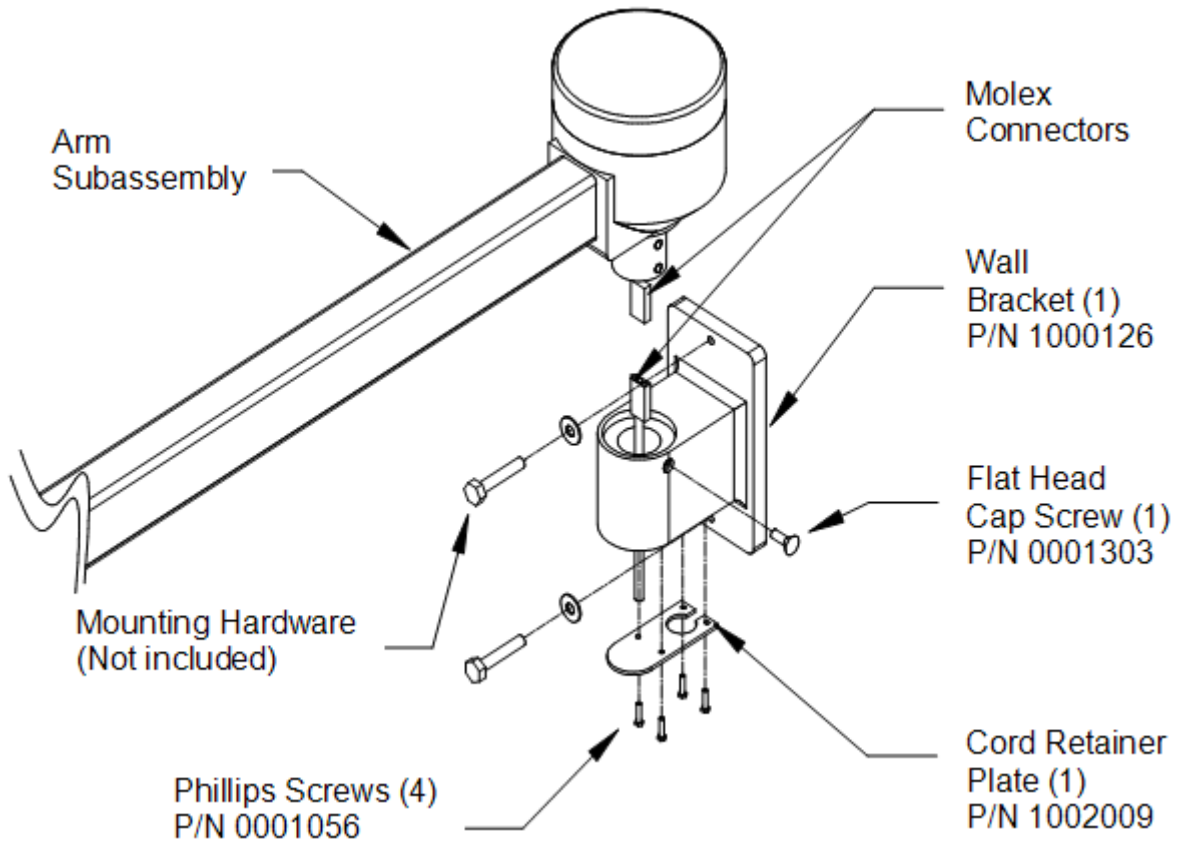

Figure 13. Wall Mount Installation

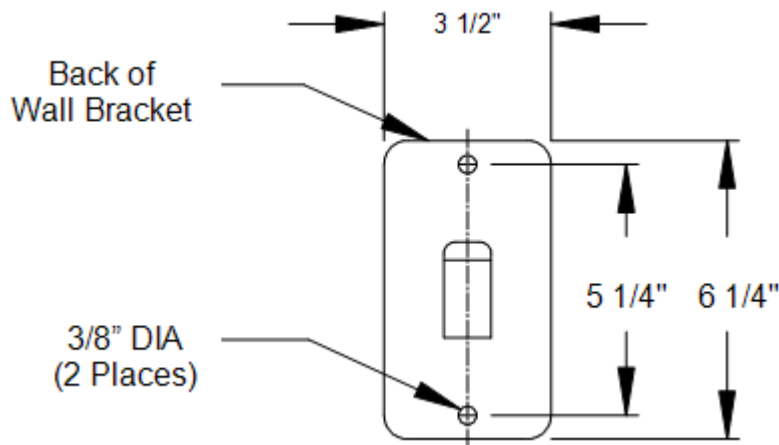

Figure 14. Wall Bracket Mounting Diagram

Wall Mounted Light Installation

⚠ Improper fastening of the wall bracket can cause serious injury and/or property damage. Make certain the installation is capable of supporting a load of at least 65 pounds and an off center moment of 195 ft-lbs.

⚠ The supply circuit line must be as follows:
100-240VAC, 50/60 Hz, single phase, three wire, capable of supplying 120 Watts @ 2A.

⚠ The equipment is not deemed compatible with any sort of electrical dimming device. Use line voltage only. To maintain proper grounding reliability, the ground wire connections with the wall bracket must be kept properly fastened at all times

⚠ Do not install the extension arm with the light head attached. Installation with the light head attached can cause damage to the light. Refer to the procedure for installing the head to the arm after the bracket and arm are installed.

Recommended Wall Structure Construction Details

The illustrations below are suggested mounting schemes per 2001 California Building Code – Section 1632A: Anchorage and Seismic. For any other mounting scheme, please consult a structural engineer and/or professional contractor for the best solution for your situation. Installation and repair of this equipment should be performed by qualified persons only. Medical Illumination does not warranty any damage occurring as a result of improper installation.

Wall mounting with load anchor or stud anchor

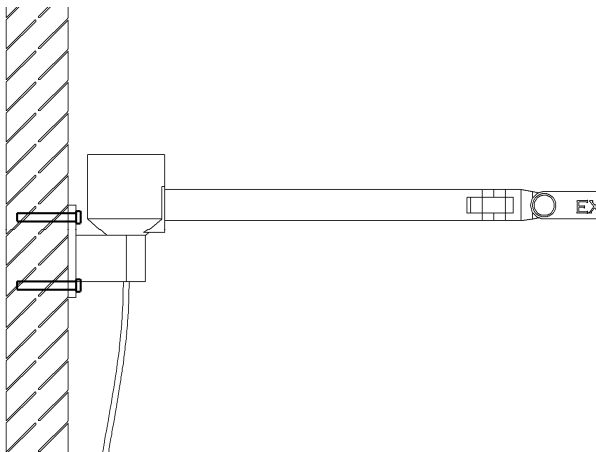

Concrete Wall (3000 PSI min., 6" thick min.):

- Use two $\frac{3}{8}$ " Dia HILTI KB3 Expansion Anchors or approved equivalent bolts (min. embed. 3"). See Figure 15. Stud Anchor Installation. Also see HILTI technical document ESR-2302 for additional concrete anchoring information.

Wall mounting with Backing Plate (not provided)

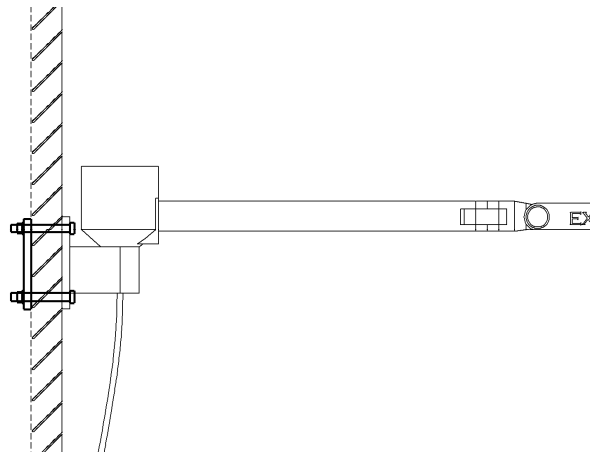

Lattice stone, cinder block, etc. (min. $\frac{5}{8}$ " wall board thickness):

- Use two $\frac{3}{8}$ " Dia A307 Bolts with nuts/washers to Backing Plate

See "Figure 13. Wall Mount Installation"

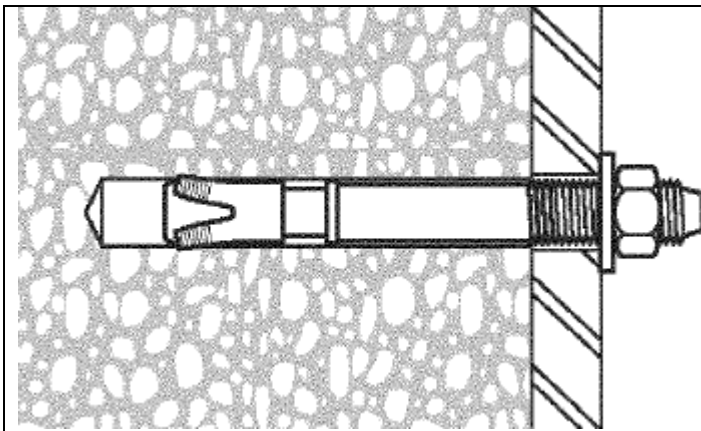

Figure 15. Stud Anchor Installation

- Drill hole according to the diameter of the stud anchor
- Thoroughly clean hole – removing all debris
- Insert anchor into hole (min. embed 3")
- Torque the nut down against the washer to 20 ft-lb (see HILTI tech. doc. ESR-2302 Table 1 for reference)

- Remove the four screws holding the cord retainer plate in place. Carefully pull the plate away from the wall bracket to expose the Molex connector. **DO NOT use excessive force during this procedure or in any way loosen or disconnect the green wires within the bracket.**



Failure to comply with local electrical codes can cause a shock hazard.

- Bring the extension arm over the wall bracket and feed the Molex connector from the transformer housing into the bracket while inserting the housing into the bracket. Secure the housing to the bracket with the flat head cap screw provided.
- Bring the cord retainer plate up to the bottom of the wall bracket and plug the Molex connector at the end of the power cord to the connector from the transformer. Route the connectors and wire to the rear of the bracket (not shown). Refasten the retainer plate to the bracket with the four screws provided.
- See the instructions for “Light Head-Arm Installation” on page 30 to complete the assembly.

Floor Stand Light Installation

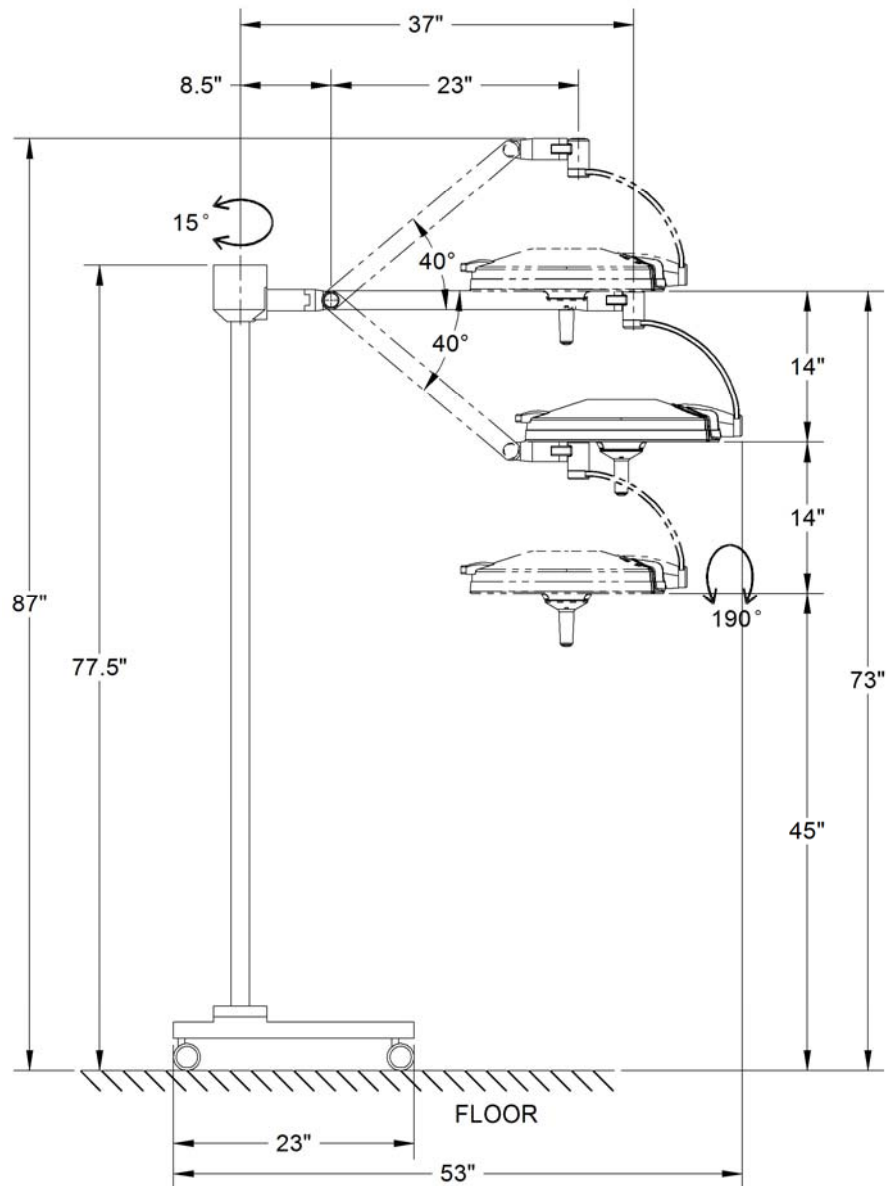

Figure 16. Floor Mount Dimensions

GENERAL INFORMATION

The shipping carton contains a light head assembly, arm assembly, floor base casting, two leg assemblies, a hardware kit, and an Installation and Service Manual. A second carton contains the upright pole assembly. Prior to installation insure that all components are present.



When removing parts from the shipping carton, be careful not to damage the components. Important: thoroughly check each box for parts that may be located in areas that can be overlooked.

Floor Stand Light Installation

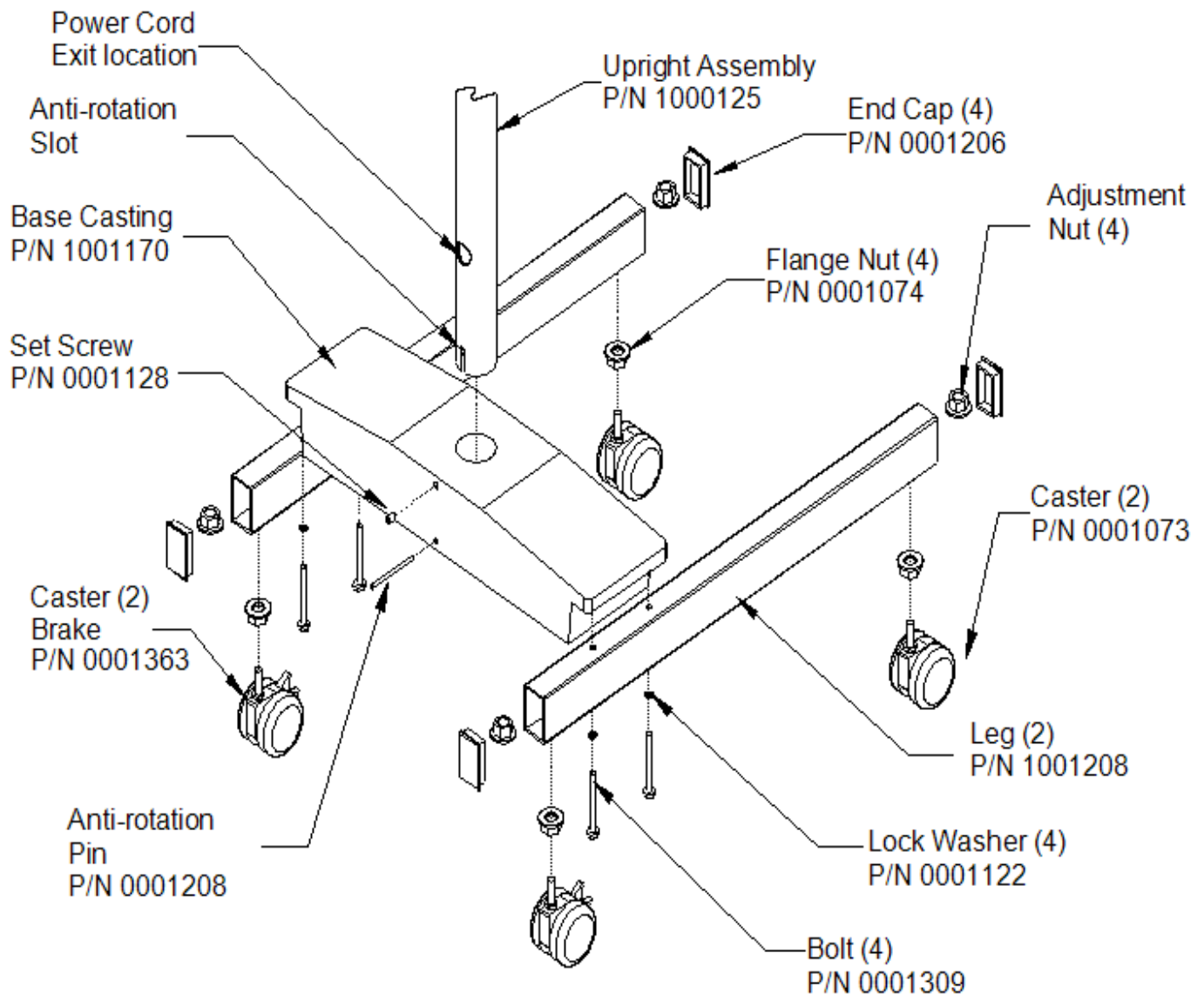

Figure 17. Floor Stand Base Installation

- Bolt the assembled legs onto the cast iron base using four $\frac{1}{4}$ "-20 x $1\frac{3}{4}$ " bolts and $\frac{1}{4}$ " lock washers. Position the floor base casting so that the set-screw in the base is at the rear of the assembly. See Figure 17. Floor Stand Base Installation.
- Insert the upright pole fully into the floor base casting so that the anti-rotation slot sits over the pin in the casting. Rotate the pole until the slots slides fully over the pin, and lower the pole completely into the base. The power cord (not shown on figure) should be in line with the set-screw. Once the pole is properly positioned, securely tighten the set-screw using the $\frac{1}{8}$ " hex key provided.



Do not install the extension arm with the light head attached. Installation with the light head attached can cause damage to the light. Refer to the procedure for installing the head to the arm after the floor mount is assembled and the arm is in place.

Arm Assembly to Upright Pole Installation

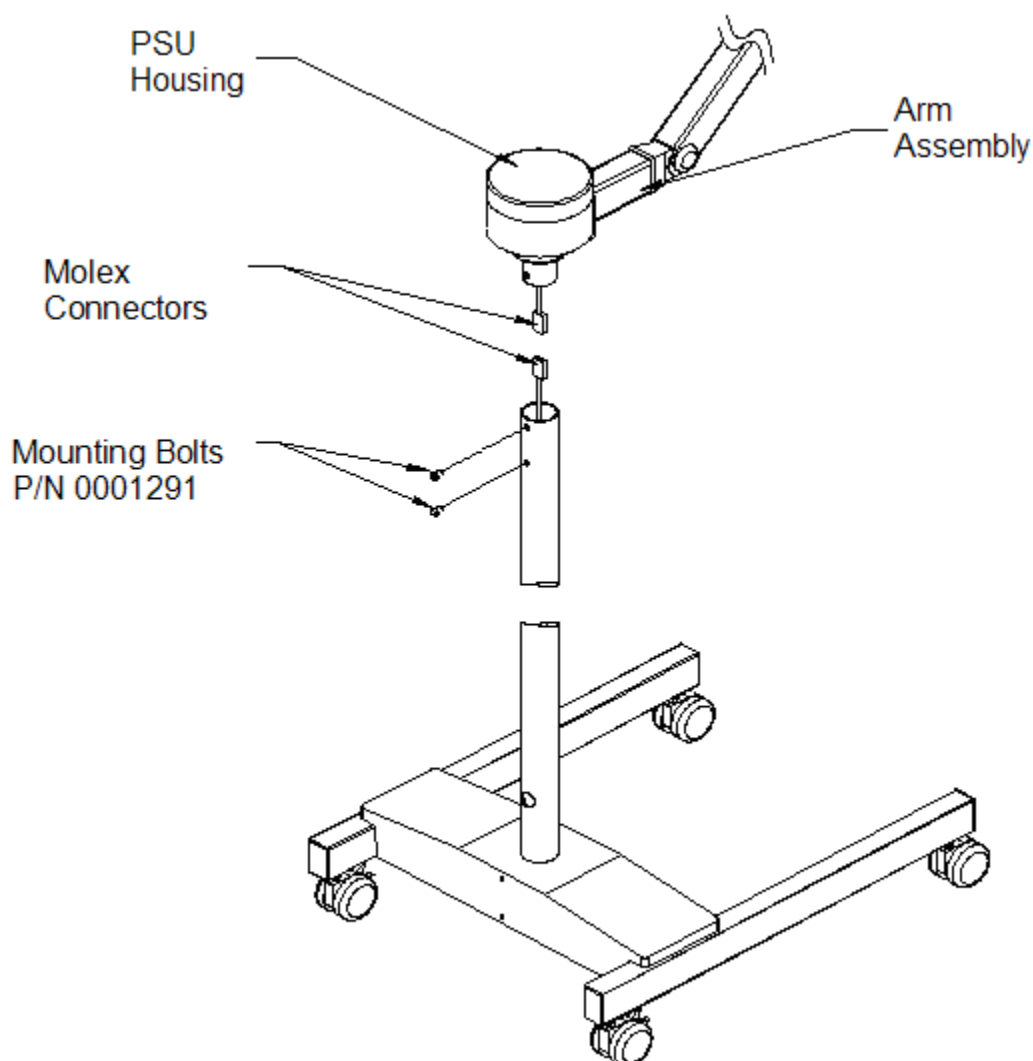

Figure 18. Arm Assembly to Upright Pole Installation

- While securely supporting the extension arm above the upright pole, firmly grasp the cable at the end of the pole. DO NOT allow the cable to slip into the pole as it may be difficult to retrieve it. Connect the Molex connector from the transformer housing to the connector at the end of the pole. Remove the cable tie holding the harness in place and discard it. Carefully lower the extension arm and insert the transformer housing into the tube while pushing the wiring into the pole. Secure the housing to the pole utilizing the two $\frac{1}{4}$ "-20 x $\frac{3}{8}$ " bolts supplied. Tighten the bolts securely.
- The light arm should be between the extended legs as shown in Figure 18. Arm Assembly to Upright Pole Installation.
- To level the base, remove the end caps at the end of each leg and adjust the caster bolts and nuts. Once the base has been leveled, tighten the nuts securely and insert the leg cap in the end of each leg. See Figure 17. Floor Stand Base Installation.
- See the instructions for "Light Head-Arm Installation" on page 30 to complete the assembly.

Light Head-Arm Installation

Figure 19. Light Head-Arm Installation

⚠ Installation and repair of this equipment should be performed by qualified persons only. Medical Illumination does not warranty any damage occurring as a result of improper installation.

- Insert the wire set from the yoke / arm connector through the hole in the arm/wire junction.

Light Head to Arm Installation

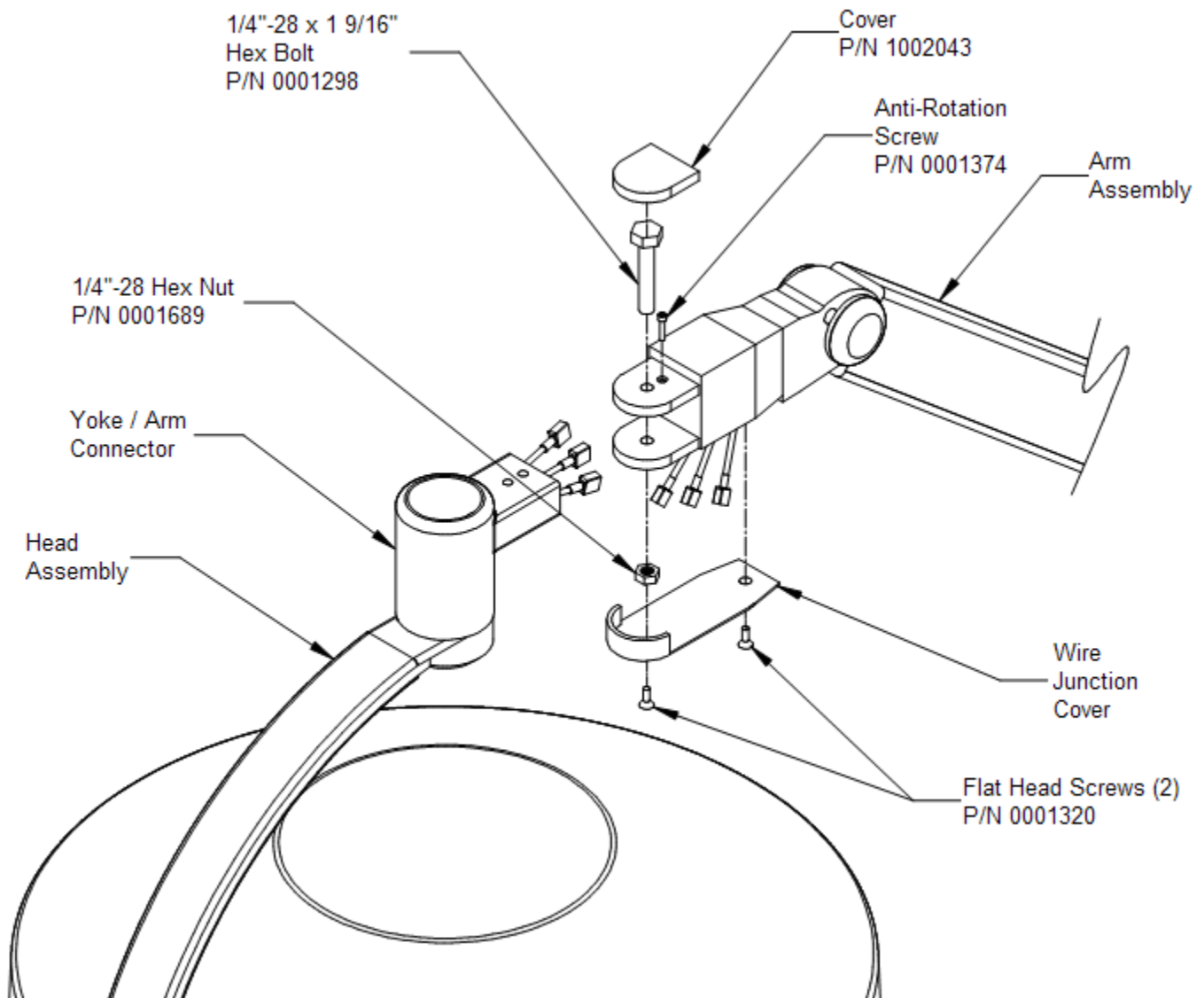
- Insert the yoke/arm connector into the arm until the bolt-holes are aligned. Insert the $\frac{1}{4}$ "-28 x $1\frac{9}{16}$ " bolt as shown being careful not to damage the wires, and secure with the $\frac{1}{4}$ "-28 hex nut. Tighten the nut securely, but do not over tighten.
- Tighten the anti-rotation screw into the yoke/arm connector using the hex key provided.
- One set of wires exits from the light head assembly, and the other set exits from the arm/wire junction assembly. Connect the wires with the spade connectors: black wire to black wire, red wire to red wire, and green wire to green wire. Replace the Connection Cover and securely tighten the two screws. See Figure 20. Light Head to Arm Electrical Connections.
- Press the snap cover onto the top of the hex bolt as shown on Figure 19. Light Head-Arm Installation.

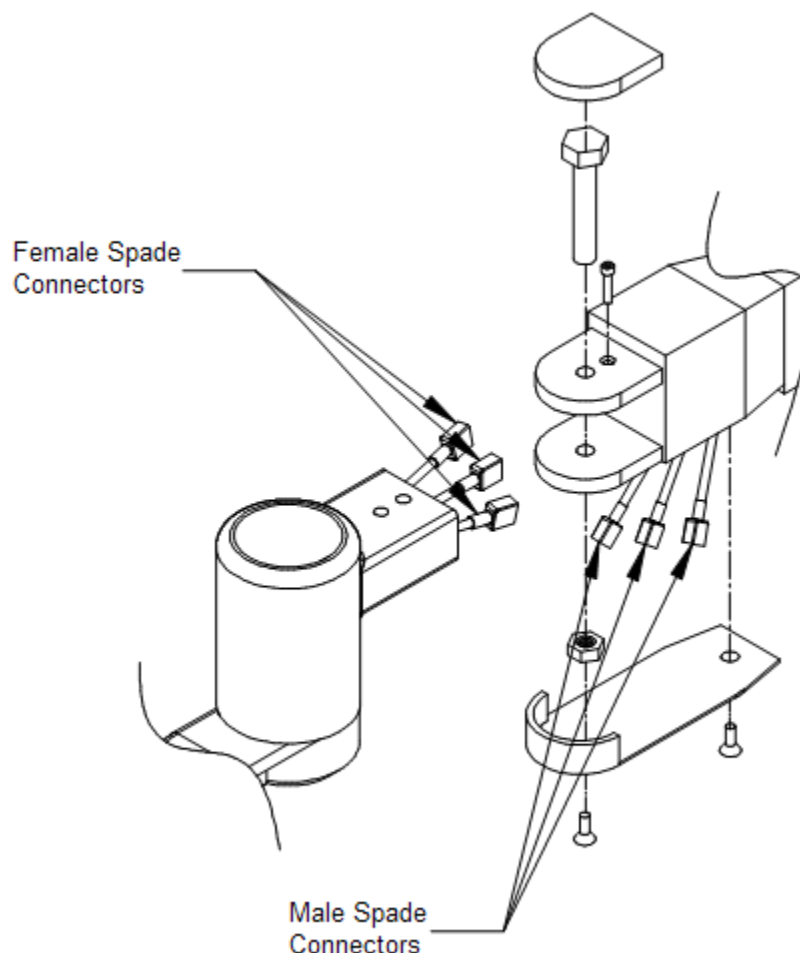

Figure 20. Light Head to Arm Electrical Connections

Chuttle Track Ceiling Track Mount

⚠ Installation and repair of this equipment should be performed by qualified personnel only. Medical Illumination International, Incorporated does not warranty any damage or injuries as a result of improper installation.

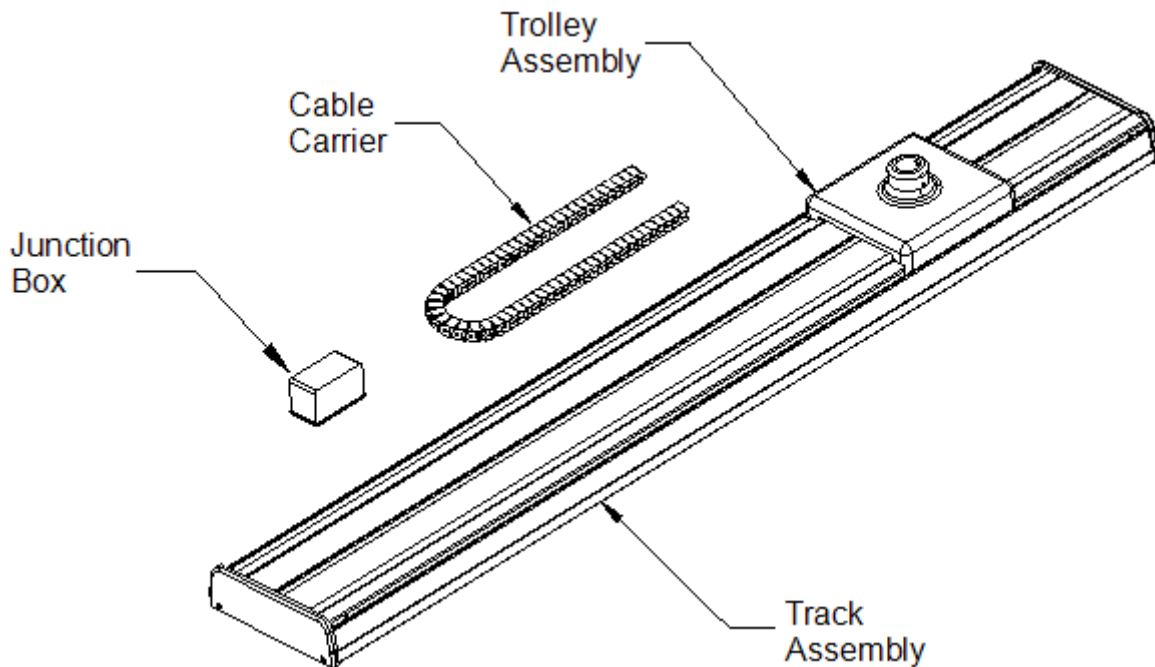

Figure 21. Track Assembly and Components

GENERAL INFORMATION

The shipping carton contains a fully assembled track mount and an installation and service manual. Carefully remove the track from the shipping carton. Check the track for any visible damage or missing components. The major components provided are the track assembly, trolley assembly, and a junction box as shown on “Figure 21. Track Assembly and Components”. Dual trolley Model No. 044012 will have two trolley assemblies and two wire harness cables. Prior to installation insure that all components are present. Some disassembly of the unit is required before mounting it to the ceiling.

⚠ Be careful not to damage any of the components when removing parts from the shipping carton.

⚠ Important: Thoroughly check each box for parts that may be located in areas that can be overlooked.

Chuttle Track Pre-Installation Requirements



Installation and repair of this equipment should be performed by qualified persons only. Medical Illumination does not warranty any damage or injuries occurring as a result of improper installation.

Before installation, check to insure the following conditions are provided and in place.

- A structural ceiling mount meeting the specifications of the architectural plans, or suggested structural mounting shown in “Figure 22. Mounting Pallet Perpendicular to Wood Joist”, “Figure 23. Mounting Pallet Parallel to Wood Joist”, “Figure 24. Mounting Pallet to a Suspended Ceiling”, and “Figure 25. Suspended Ceiling Wood Bracing Detail (End View)”. The installation must be capable of supporting a weight of at least 225 pounds and an off center load of 565 ft-lbs.
- The track mount should not be mounted higher than 9 feet 6 inches (9 ½ feet) above the floor. The track mount must be mounted at the finished ceiling level whether the ceiling surface is solid or “dropped” type. Mounting the unit higher than 9 ½ feet may result in instability of the light system and the arm assembly mounted too high to be accessible.
- Check the length of the ceiling rod supplied (located in the carton with the light head and arm). The rod lengths available for the Chuttle Track are 16” long for a mounting height of 7 feet 6 inches to 8 feet 6 inches. A 25” long rod is available for a mounting height of 8 feet 7 inches to 9 feet 6 inches. If a problem occurs, contact our customer service department at (818) 838-3025.
- The mounting bolts used to fasten the track must be able to support a minimum of 225 pounds each ($\frac{3}{8}$ ” diameter bolts required).

Chuttle Track Pre-Installation Requirements

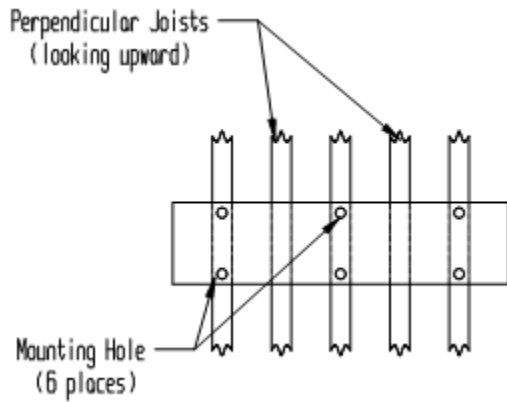

Figure 22. Mounting Pallet Perpendicular to Wood Joist

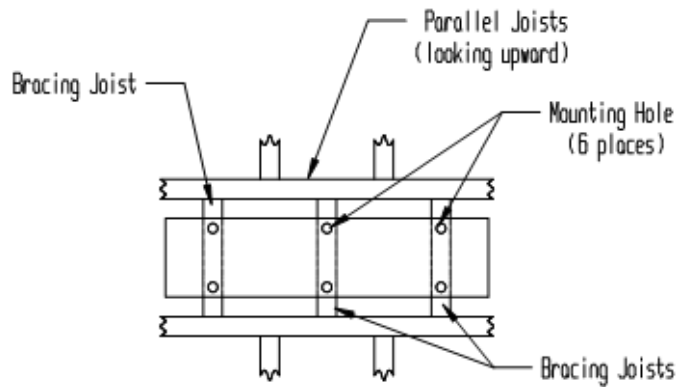

Figure 23. Mounting Pallet Parallel to Wood Joist

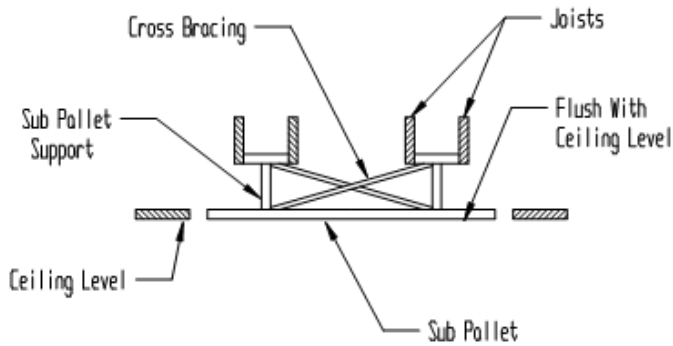

Figure 24. Mounting Pallet to a Suspended Ceiling

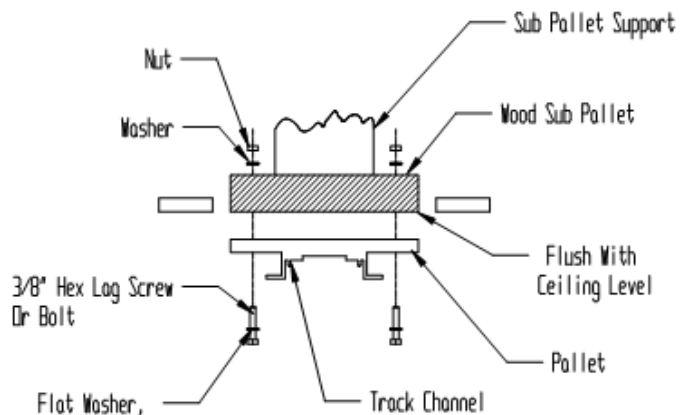

Figure 25. Suspended Ceiling Wood Bracing Detail (End View)

Disassembly of the Track Mount Before Installation

⚠ Note: For installations where there are two existing trolley assemblies on a single track (Dual Trolley Model No. 044012), the left and right trolley must be removed from the track from their respective sides. When disassembling the track, remove both end plates from the unit. Remove the right trolley from the right side and the left trolley from the left side of the track.

⚠ Do not mix the right and left trolley assemblies. The cord bracket within each trolley is positioned to make electrical connection for the right and left light fixtures respectively. Medical Illumination International, Inc. recommends temporarily marking each trolley if needed to make sure these are assembled onto the track in the proper location and orientation.

⚠ When performing this procedure DO NOT disassemble the components of the trolley assembly or remove the track extrusion channel from the plywood pallet.

- Take the end plate/plates P/N1001511 off the side of the track by unfastening the two (2) #6 wood screws. See Figure 26. End Plate Removal.

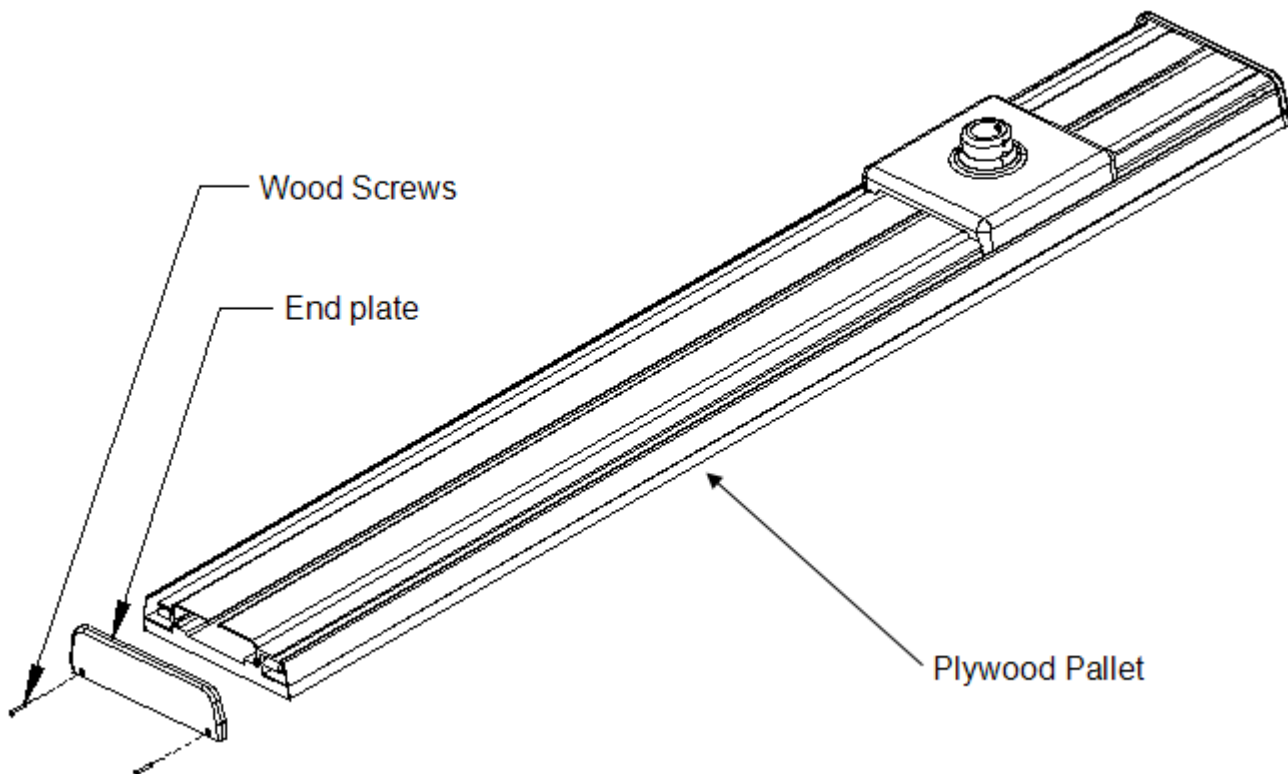

Figure 26. End Plate Removal

Disassembly of the Track Mount Before Installation

- Take off the two side panels P/N 1001516 by removing the two (2) #10 wood screws at the end of each panel. See Figure 27. Side Panel Removal.

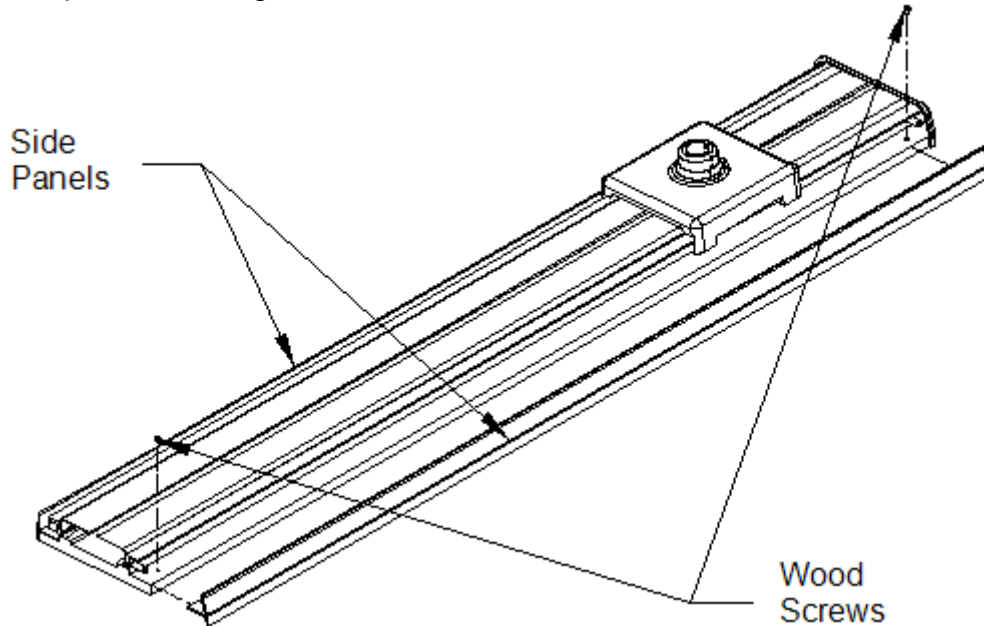

Figure 27. Side Panel Removal

- Loosen the three #8 set screws along each side of the track channel extrusion P/N 1001500 with the provided hex Allen wrench. Remove both dress covers P/N 1001515. See Figure 28. Dress Cover Removal.

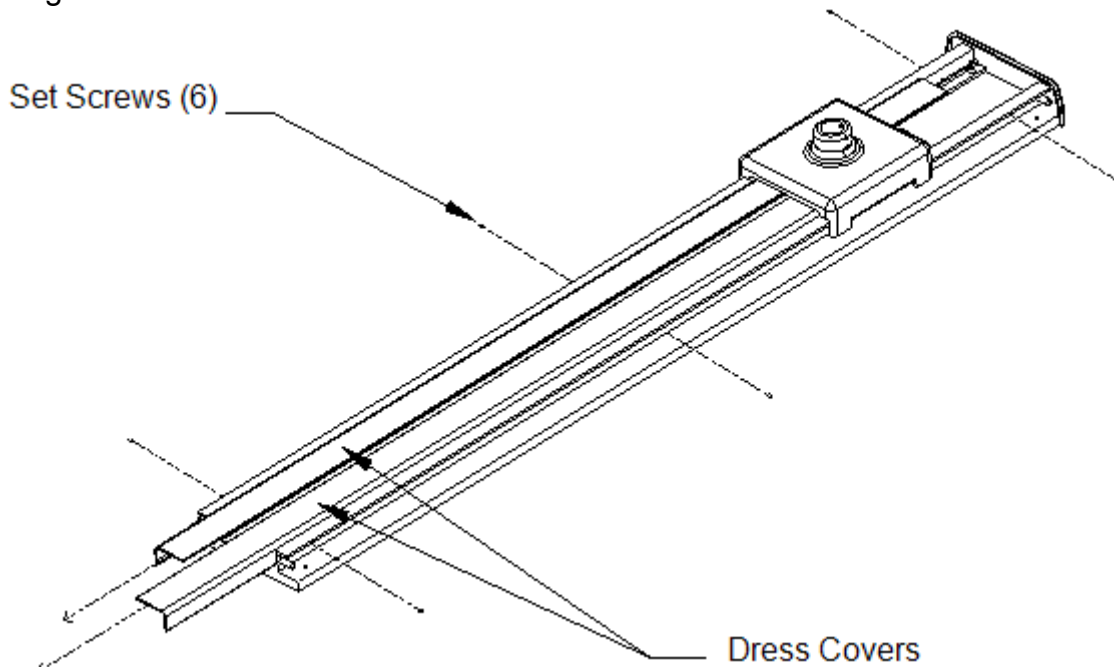

Figure 28. Dress Cover Removal

Disassembly of the Track Mount Before Installation

! Keep the side panels and dress covers in a safe place to prevent damage until reassembly.

- Remove the two stop pins P/N 1001076 and the #6 flat head screws P/N 0001155 holding the pins in place from the track end with the end plate already removed. See Figure 29. Stop Pins Removal.

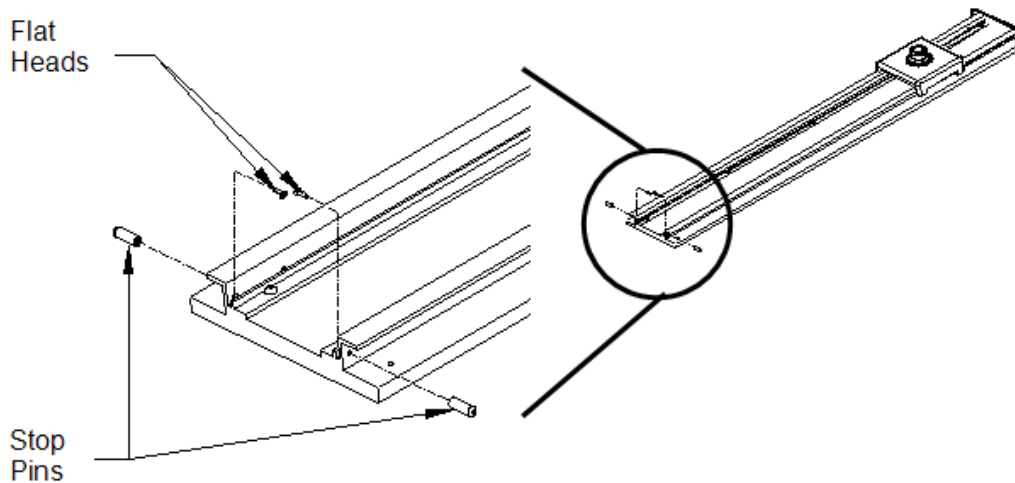

Figure 29. Stop Pins Removal

! Secure all screws and hardware until it is time for reassembly.

! Disconnect the Molex connector attached to the trolley first.

- Slide the trolley assembly P/N 1000187 off the track. See Figure 30. Trolley Assembly Removal.

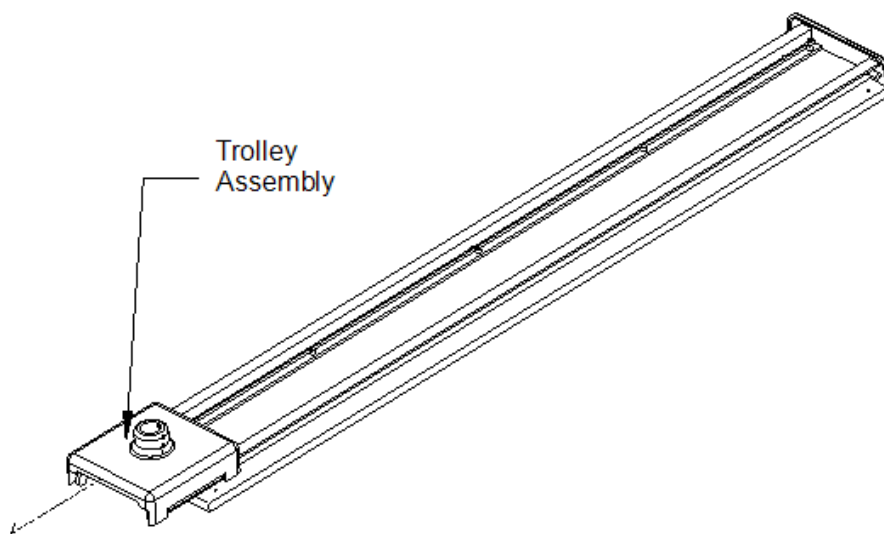

Figure 30. Trolley Assembly Removal

Track Mount Installation Procedure



Warning: Improper fastening of the track mount can cause serious injury and/or property damage. Insure the installation is capable of supporting a weight of at least 250 pounds and an off center load of 625 ft-lbs.

- It is recommended that the head of each mounting bolt be recessed flush or just below the surface of the plywood pallet. This will allow for easier assembly of the side panels once the track is mounted. Drill six (6) $\frac{7}{16}$ " diameter clearance holes in the plywood pallet for the bolts. Counterbore the holes to 1" diameter by $\frac{3}{8}$ " deep. The holes should be evenly spaced along the pallet at the outside edge of the track base extrusion.



Note: The fasteners can also be placed in the interior of the track extrusion if ceiling conditions do not allow mounting the fixture at the plywood pallet.

- Mark the hole locations on the ceiling structure to match the hole locations on the plywood pallet. Drill the proper sized pilot or clearance holes in the ceiling structure depending on the type of fastener that has been chosen.



Note: The next step requires two people to mount the track base. One person is needed to support the fixture at the ceiling while the other person fastens the bolts.



Failure to use two people could result in equipment damage and/or personal injury.



Proper movement of the trolley requires the track to be mounted to a level ceiling structure. Check the ceiling with a leveling device in the length and width directions before mounting the base.

- Install the base to the desired location with six (6) $\frac{3}{8}$ " diameter by 4" (minimum length) hex bolts with flat washers or hex lag screws with washers (hardware is not provided). If shimming is required ($\frac{1}{4}$ " or less), flat washers can be placed between the track pallet and the ceiling surface to achieve a level installation.
- An electrical junction box is provided if one is not available in the ceiling. Fasten the box as close as possible to the power cable exiting the back of the track. Route the cable from the track to the junction box then connect the power source to the cable (figure not shown).



Note: A ground wire is provided and must be fastened to an earth ground to insure proper grounding reliability for the lighting fixture(s). Wire routing and connections must be done in accordance to local and national electrical codes.

Track Mount Installation Procedure

- Remove the ¼" by 2" roll pin taped down in the trolley assembly. Insert the pin into the ceiling rod end that has one hole in both walls. The pin should extend the same amount on both sides of the ceiling rod. Install the ceiling rod into the trolley and allow the roll pin to rest in the indentation in the trolley. See Figure 31. Ceiling Rod and Roll Pin Installation.



Failure to install the roll pin correctly can cause serious injury and/or property damage.

- Secure the ceiling rod by tightening the four ¼"-20 set screws in the trolley hub. Insert the wire harness exiting the trolley through the ceiling rod. The large Molex connector from the wire harness must be located at the roll pin end. Insert the connector into the cord bracket attached on the trolley's bottom until it locks in place.

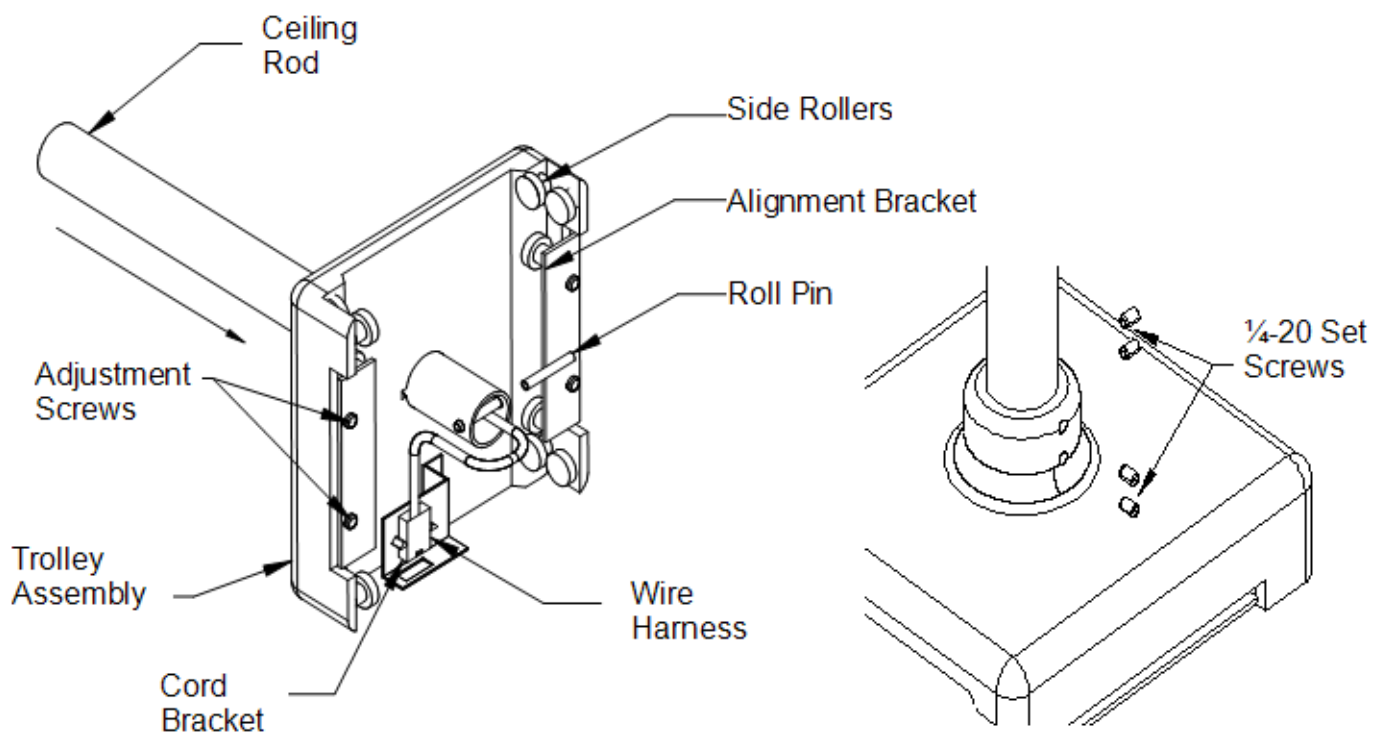

Figure 31. Ceiling Rod and Roll Pin Installation

- Slide the trolley with the installed ceiling rod back onto the track. The cord-mounting bracket in the trolley should be positioned so it is next to the mating Molex connector on the power cord. Insure that the trolley rolls freely along the track. If adjustment is necessary loosen the adjustment screws and position the side rollers against the base track extrusion as shown on "Figure 31. Ceiling Rod and Roll Pin Installation". Retighten the screws.



Ensure the power cord does not get twisted when attaching it to the cord bracket on the next step. Do not proceed with the installation before correcting the problem.

Track Mount Installation Procedure

- Ensure the cable carrier chain lays flat within the track. Attach the Molex connector to the mating connector on the trolley assembly. See “Figure 31. Ceiling Rod and Roll Pin Installation” and “Figure 32. Power Cord Placement”

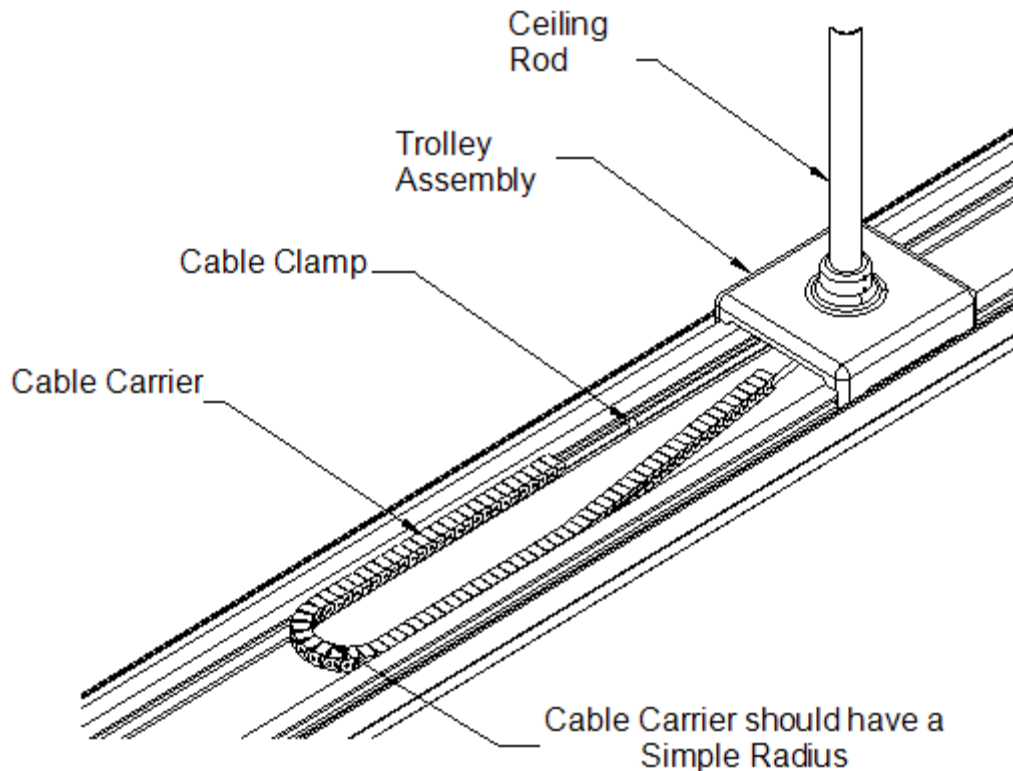

Figure 32. Power Cord Placement

- If the cable carrier and trolley move properly along the track, replace the two stop pins and screws at the open track end. Carefully slide the center dress covers through the trolley. Be careful not to damage the trolley components, wire connections, or the covers when installing these back. Tighten the three set screws along both sides of the track to secure the covers in place.
- Reinstall the side panels and secure in place with the wood screws. Ensure the holes in the pallet are aligned with the holes in the side panel before fastening. Reinstall the end plates.



Note: If the bolt heads were not previously set flush with the plywood, clearance holes need to be drilled in each panel to allow these to sit against the plywood pallet.

- Refer to “Section 3: Installation/Assembly” in this manual to install the light fixture(s) to the end of the ceiling rod. Refer to “Single Ceiling Mount Installation” or “Double Ceiling Mount Installation” accordingly.

Section 4: Operating Instructions

MI-1000 Operation

- Power / Dimmer Button: Press button to energize or hold button for 3 seconds to de-energize lamp. While energized, press and release button to cycle thru the 5 level of dimming (100% - 87% - 75% - 63% - 50% - 100% - 87% - ...).
- To position the light head and arm over the work area, firmly grasp the sterilizable handle or the handle located on the side of the housing and bring the light head or arm to the desired location. Adjust the tilt of the light head by holding the sterilizable handle and rotating forward or backward. The light head can revolve around the Yoke/Arm connector by grasping the side handle or yoke and moving it in a circular motion.

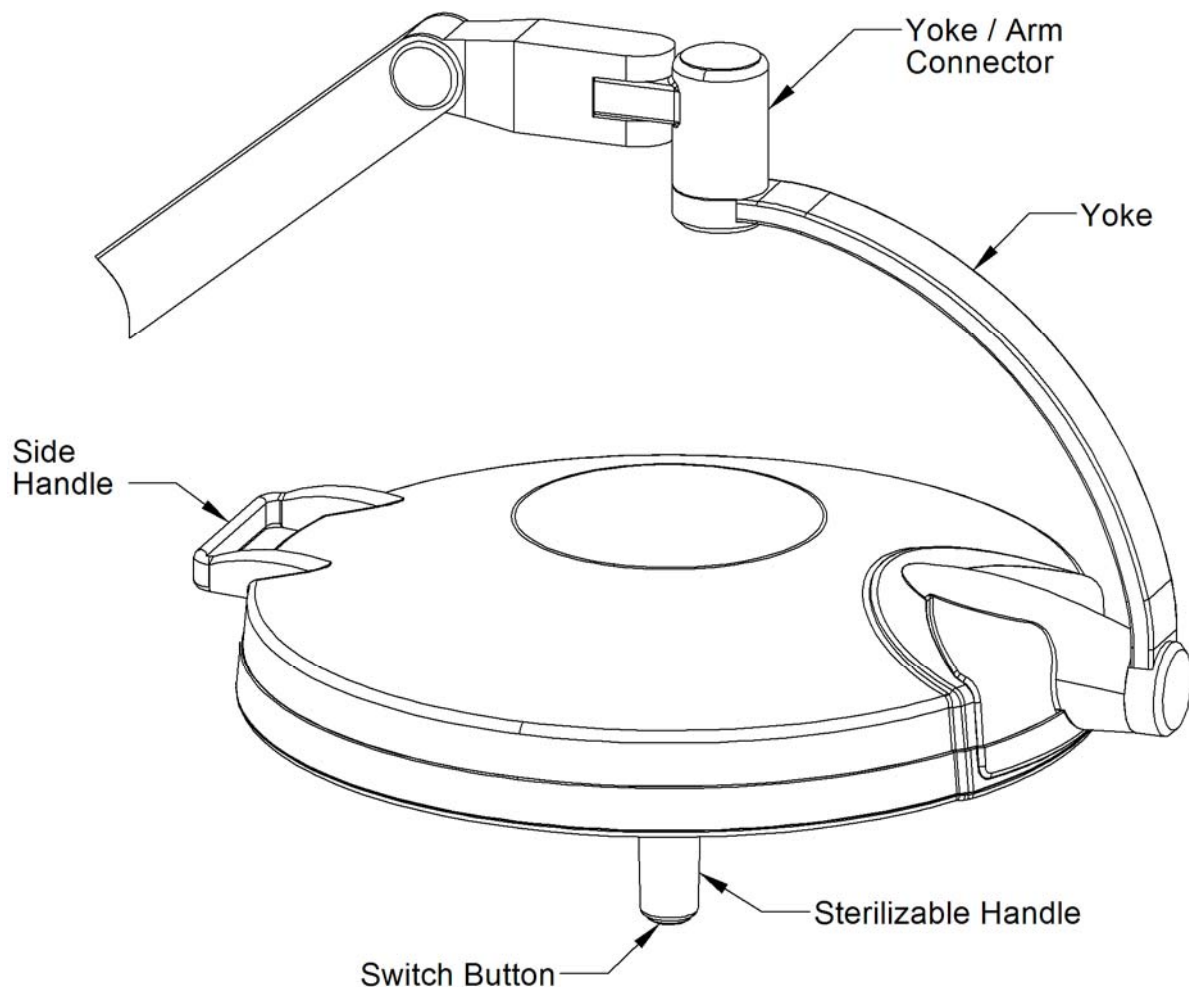

Figure 33. MI-1000 Operation

Section 5: Safety Instructions

Safety Tips



Only facility authorized maintenance personnel should troubleshoot the unit. Troubleshooting by unauthorized personnel could result in personal injury and/or property damage.



Only facility authorized personnel should repair the unit. Repair by unauthorized personnel could result in personal injury and/or property damage and could void warranty.



After completing a repair of the unit, ensure the unit is in proper working order. Failure to do so could result in personal injury and/or property damage.



Do not touch the LED's or lenses directly. Body oils may significantly lower the optical performance of these parts and may cause equipment damage.



Follow the product manufacturer's instructions. Failure to do so could result in personal injury and/or property damage.



If the unit fails any part of the preventive maintenance functional checks, repair the unit before use on any patient. Failure to do so could result in personal injury and/or property damage.



Do not use harsh cleaners, solvents, or detergents. Failure to do so could result in equipment damage.



Do not use silicone-based lubricants. Equipment damage could occur.



Turn the power off or unplug the power cord before any repairs are started. Failure to do so could result in personal injury and/or property damage.



Do not pinch any wires during installation or during any repair. Pinched wires can cause an electrical shock hazard, resulting in personal injury and/or property damage.



Do not expose the unit to excessive moisture. Failure to do so could result in personal injury and/or property damage.

Section 6: Maintenance

LED Lamp Maintenance

- The LED life (L70) is rated such that the LED will deliver, on average, 70% lumen maintenance at 50,000 hours of operation. (approximately 17 years @ 8hr/day)



If one or more LED(s) are off and/or generate noticeably dim light output, contact our customer service department at (818) 838-3025. **The LEDs are not readily replaceable by end users and should only be serviced by Medical Illumination or facility authorized maintenance personnel.**

Arm Adjustment



The arm has been pre-adjusted by the factory. Should further adjustment be necessary, utilize the following procedure.

- Release the arm friction brake by loosening the set screw inside the Friction Adjustment Hole with an Allen wrench (3 or 4 turns). This allows the spring to move freely for a more accurate adjustment. The arm is expected to droop as the brakes are loosened.
- Remove the white rubber Cover from the spring tension adjustment slot as shown.
- Move the arm vertically until the adjustment nut is visible down inside the Slot.
- Engage the tabs of the Adjusting Wrench into the slots in the Adjustment Nut. Turn the nut in the direction of the arrow as shown in the figure to increase the arm tension. Check the progress as you go until the required adjustment is reached.



Do not over tighten the nut. Doing so could result in equipment damage.

- When proper tension is achieved, the arm should travel up or down an equal distance when the same amount of force is applied from above or below. When moved to the maximum Up position, it should travel back down about 1-1.5 inches (until brake is set). From maximum Down position, it should travel back up about the same.
- After the spring tension is adjusted, re-tighten the brake until the desired resistance is obtained.
- Replace the spring tension adjustment slot cover.

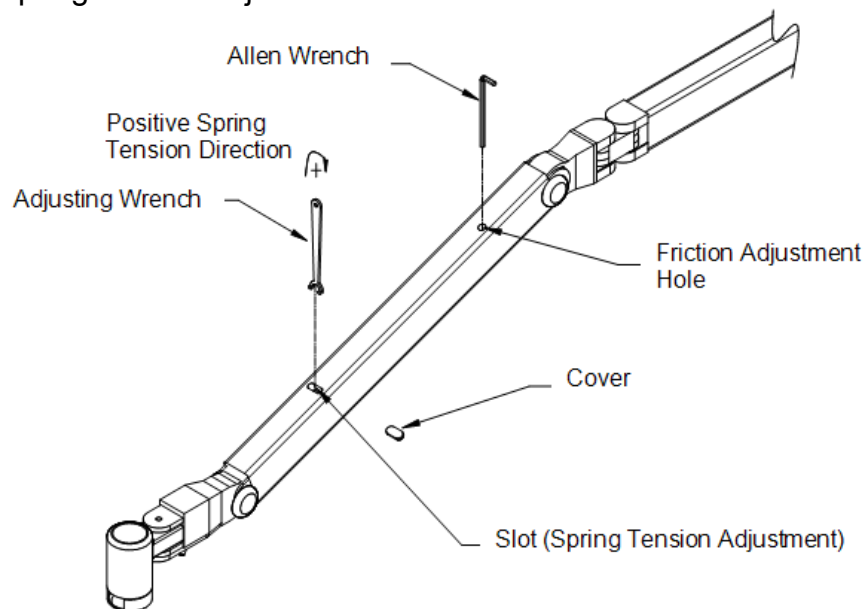

Figure 34. Arm Adjustment

Head/Yoke Adjustment

⚠ The head/yoke has been pre-adjusted by the factory. Should further adjustment be necessary, utilize the following procedure.

- Find the yoke cap as shown in a heavy circle below. See Figure 35. Head / Yoke Adjustment.
- Cradle the sides of the cap with your thumb and index finger. Squeeze and then pull out the yoke cap to expose the nut, or gently pry off with a flat bladed screwdriver.
- Use a wrench or pliers to tighten the nut as shown. Add thread-locking liquid (e.g. Loctite) around the inside of the nut if the nut continues to loosen during yoke rotation.

⚠ Do not over tighten the nut. Doing so could result in equipment damage.

- Push the yoke cap back into its original position.

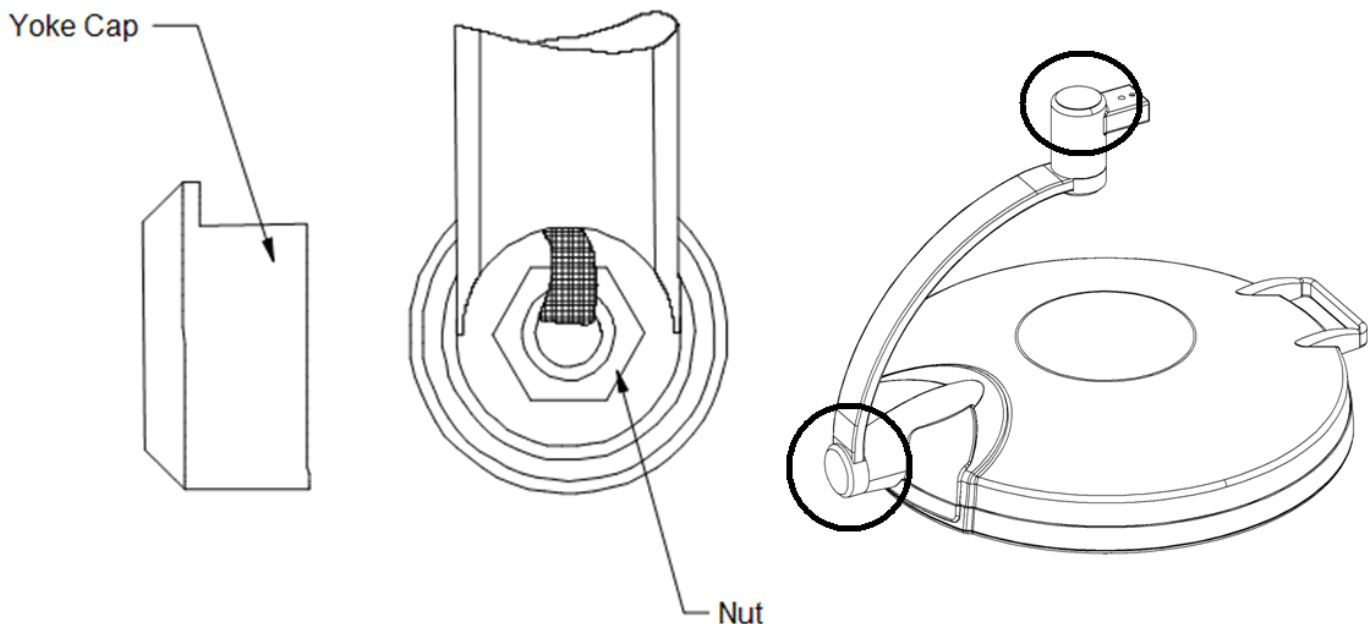

Figure 35. Head / Yoke Adjustment

Handle Sterilization

- Remove sterilizable handle by pressing the button near the base of the handle and pulling the handle off the handle post. See Figure 36. Handle Sterilization.
- Sterilize the handle utilizing steam sterilization of minimum 250° Fahrenheit for a minimum of 30 minutes in compliance with AAMI-SSSA-1988: Good Hospital Practices, Steam Sterilization and Sterility Assurance, or an approved equivalent method.

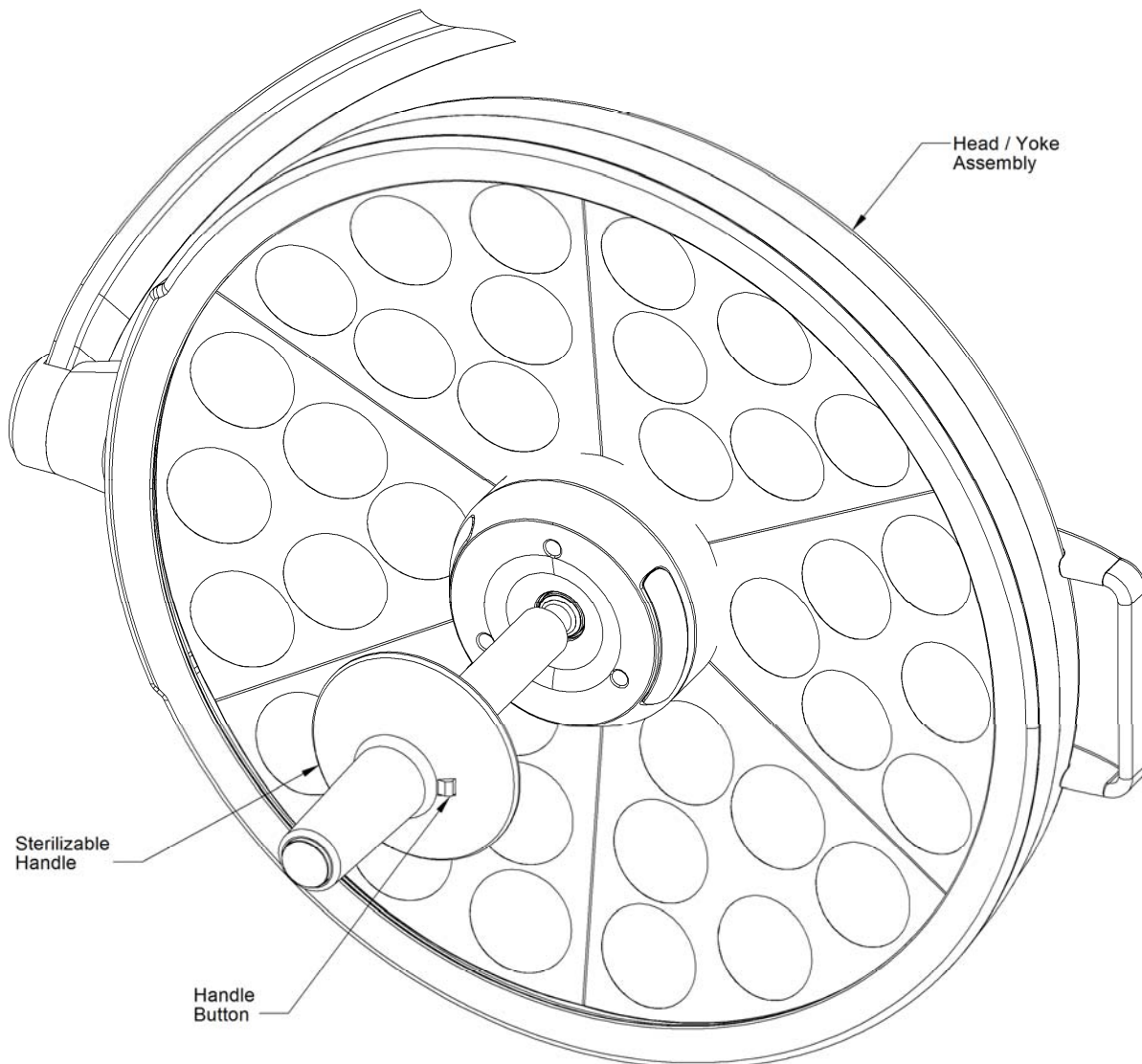

Figure 36. Handle Sterilization

Cleaning Instructions



Units operate at high temperatures. Allow the unit to cool at least 30 minutes before performing any maintenance. Failure to do so could result in personal injury.

- Clean the lens using glass/plastic cleaner or mild soap and water mix. It is very important to use a clean, soft cloth to avoid any scratching of the front lens. Never spray the cleaning fluid directly onto the lens surface, but instead spray into clean cloth and then wipe the lens.
- Clean the light housing and arm(s) using mild soap and water mixture. Apply this mixture to a clean cloth and wipe down the light-head and arm. Never spray the cleaning fluid directly onto the light head or arm.



Do not use harsh cleaners, solvents, or detergents. Failure to do so could result in equipment damage.



The MI-1000 front lens is supplied with a protective hard coat to resist scratching. Never use abrasive cleaners on front lens. Failure to do so could result in equipment damage.



Do not expose the unit to excessive moisture. Failure to do so could result in personal injury and/or property damage.

Maintenance Schedule

Function	Procedure
Front lens/Optics	Check front lens and optics to assure there are no chips, cracks, or other damage. Do not use equipment if parts are damaged. Replace damaged parts immediately.
Bolts and nuts	Check to see that all mounting and attachment screws, washers, etc. are in place and securely tightened. Replace any missing screws and re-tighten as required.
Casters	Ensure that casters are seated properly on the base assembly. Examine the base for any damage.
Moving joints/Adjustments	Check to make sure all moving joints function properly along the mounting system and head and arm system. If the articulating arm does not position properly (drifts from original position) refer to "Figure 34. Arm Adjustment" on page 44. If this does not solve the problem contact customer service as the unit may require factory repair.
Overall appearance	Check the general aesthetics. Units should be kept clean and dust free. Clean and dust as necessary.



Note: Maintenance schedules vary for each light depending on usage and operating instructions. An annual inspection of the equipment is recommended at a minimum.



Note: Medical Illumination International Inc. recommends that the maintenance records for this equipment be kept on file at the health care facility.

Section 7: Troubleshooting

General Troubleshooting



Warning: Disconnect the light from the power supply before attempting any of the electrical checks mentioned below.

Problem	Cause	Remedy
Light will not turn on or stay on	<ol style="list-style-type: none"> 1. Power to unit is off (not plugged in). 2. Exposed wires are cut or damage. 3. Wire not connected correctly during installation. 4. Wire connections made during installation have disconnected. 5. No input power to light unit. 6. Disconnected wires at switch or PSU. 7. No power output from PSU when input power to PSU is measured. 8. Wire connections made during installation have been reversed. 9. Sterilizable handle button not engaging power push button switch properly. 	<ol style="list-style-type: none"> 1. Turn on power (plug in unit). 2. Replace wire assembly. 3. Check all wiring connections. 4. Reconnect wires per the instructions. 5. Check power input connections and circuit breakers. 6. Reconnect wires. 7. Replace PSU. 8. Connect proper wires together: black-black and white-white. 9. Take off sterilizable handle and inspect handle post assembly with switch. Make sure handle post is tightly assembled. Make sure the button in the sterilizable handle can move freely.
Light does not maintain its position vertically	<ol style="list-style-type: none"> 1. Spring tension is incorrect. 2. Additional equipment was added to unit. 	<ol style="list-style-type: none"> 1. Adjust spring (see Arm Adjustment page 44). 2. Remove additional equipment from arm.
Light does not maintain its position horizontally	<ol style="list-style-type: none"> 1. Mounting bracket is not level. 2. Hex nuts on pivot bolts are loose. 	<ol style="list-style-type: none"> 1. Adjust or shim as necessary. 2. Remove plastic caps and adjust as necessary.
Light head will not rotate at yoke interface	<ol style="list-style-type: none"> 1. Light head is against internal stop. 	<ol style="list-style-type: none"> 1. Rotate head in opposite direction.
Arm cannot be moved any lower	<ol style="list-style-type: none"> 1. Arm is against internal stop. 	<ol style="list-style-type: none"> 1. Rotate arm in opposite direction.
Arm cannot be raised any higher	<ol style="list-style-type: none"> 1. Arm is against internal stop. 	<ol style="list-style-type: none"> 1. Rotate arm in opposite direction.
Arm stopped moving horizontally	<ol style="list-style-type: none"> 1. Arm is against internal stop. 	<ol style="list-style-type: none"> 1. Rotate arm in opposite direction.
Caster/casters cannot be reinstalled	<ol style="list-style-type: none"> 1. Floor base has been damaged. 	<ol style="list-style-type: none"> 1. Contact Customer Service or Field Representative.
Upright rotates in floor stand	<ol style="list-style-type: none"> 1. Upright set screw is loose. 2. Upright is not fully seated on anti-rotation pin. 	<ol style="list-style-type: none"> 1. Securely tighten set screw. 2. Reinstall upright. Ensure the upright fully seats on the anti-rotation pin seats.
Light output is irregular in shape or intensity	<ol style="list-style-type: none"> 1. Input voltage does not correspond to rating label. 2. The light head is not mounted on the proper arm (Combo models). 	<ol style="list-style-type: none"> 1. Check circuit to which light was installed. 2. Remount light head on the correct arm.