

Medical Illumination International, Inc. Limited Warranty

The following comprises the general terms of your product's Limited Warranty. By accepting the shipment of the product, the owner/purchaser agrees to adhere to the warranty terms and conditions expressed herein.

Medical Illumination International, Inc. ("Medical Illumination") Lighting Equipment is warranted against defective material and/or workmanship, excluding normal replacement parts (e.g. sterilizable handles), for a period of three (3) years from the date of shipment. This Limited Warranty applies exclusively to the repair or replacement of parts recognized as defective by Medical Illumination that are in normal use and have not been modified or repaired by unauthorized personnel.

This Limited Warranty extends only to the first retail purchaser of a product, and is not transferable or assignable. This warranty supersedes all other guarantees or warranties, expressed or implied.

WARRANTY SERVICE & REPAIRS

Medical Illumination does not provide (or give any compensation for) outside repair services or field labor. Therefore, in the event of a failure covered under this warranty, please take the following immediate action:

1. Contact Medical Illumination via phone at (818) 838-3025, through our website at <http://www.medillum.com>, or by facsimile at (818) 838-3725.

A. Be prepared to give the model number, serial number, and full description of the failure.

B. Our Customer Service department will attempt to solve the problem over the phone. If it becomes necessary to send the product to the factory for repair, you will be provided with a Return Authorization number. Products sent to the factory without a Return Authorization number will not be accepted.

2. It is the retail purchaser's obligation to arrange for shipment return of a product to the factory for warranty service, which shall be at the retail purchaser's expense. Carefully package the light component (light head, arm assembly, mount assembly, etc.) and return it, freight prepaid and insured, with the Return Authorization number clearly marked on the outside of the box, to:

Medical Illumination
547 Library Street
San Fernando, CA 91340
RA# _____

When returning product for repair, damage resulting from inadequate packing is not covered by this warranty. In addition, shipping insurance does not cover damage due to inadequate packing. We recommend that the package be insured against loss or in-transit damage. Medical Illumination cannot be held responsible for in-transit loss or damage. In the event that freight-related damage should occur, Medical Illumination will notify you immediately so that you can file a damage claim with the proper freight carrier.

Within the aforementioned time period of three (3) years from date of shipment, Medical Illumination will evaluate the returned product, repair as appropriate, and ship the product back to you with freight costs prepaid by the Company. In the event that non-warranty damage or failure is discovered, you will be contacted before any repairs are performed.

EXCLUSIONS

This Limited Warranty does not cover the following:

- Any field labor or outside services (electricians, contractors, installation services, routine maintenance or other repair services)
- Damage to the product resulting from tampering, accident, abuse, negligence, alteration, or other causes unrelated to problems with material and/or workmanship
- Damage due to improper installation, use, cleaning or maintenance, as outlined in the Installation and Service Manual for the product
- Labor costs associated with removing, re-packaging for shipment or reinstalling product

PRODUCT RETURNS:

Please contact the authorized dealer from whom the product was purchased to inquire about a product return. Additional terms and conditions set by the dealer may apply for any returned items.

SHIPMENT DAMAGE:

If the initial shipment of your purchased product arrived in damaged condition, please leave the packaging and its contents intact and contact Medical Illumination immediately.



USER GUIDE FOR MI-150 EXAM LIGHT



Medical Illumination International
547 Library Street
San Fernando, CA 91340
(818) 838-3025

Intended Use: General Lighting Applications

Specifications:

Light Intensity	15,000 LUX at 24"
LED Type/Life	CoB / 50,000 hours
Operating Voltage:	100VAC-240VAC/50-60Hz
Light Head Input Voltage	24VDC
Warranty.....	3 years (limited)

Component Checklist:

MI-150 Light Head / Flexible Neck.....	1
Upright.....	1
Floor Base.....	1
Power Supply Module	1

Unpack the components and assemble as follows:

Attach the Upright to the Floor Base:

Lower and threaded side of the Upright into the Base and securely tighten with the Washer and Nut.

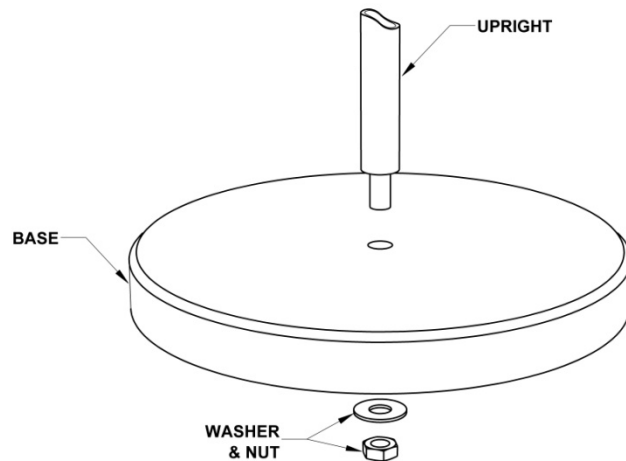

Attach the Flexible Neck to the Upright:

Position the Light Head/Flexible Neck onto the top of the upright and thread onto the upright until tight.



Attach the power:

Plug the Power Cord into the receptacle on the Flexible Neck/Power Input Module and then plug the Power Supply into the wall receptacle. Use the rocker switch at the back of the unit to turn on/off.

Operating, Positioning and Cleaning the Light:

- The switch at the rear of the light provides for ON-OFF function.



- To position the Light Head, securely hold the Flexible Neck with one hand and position the Light Head to the desired position with the other hand.
- Use mild soap and water to clean the exterior of the light. Never use harsh detergents or chemicals.